



PRO™ Xs

manual and automatic electrostatic guns



Better Finish
Operator Comfort
Save Time
Material Savings



PRO Xs gives you:

- A FULL RANGE OF ELECTROSTATIC SPRAYING CAPABILITIES
- AN AIR-POWERED GUN FOR EASY INSTALLATION AND SERVICE
- ELECTROSTATIC SPRAYING AT A LOWER PRICE POINT
- LOW COST OF OWNERSHIP
- A 3-YEAR WARRANTY ON POWER SUPPLY, BARREL AND HANDLE

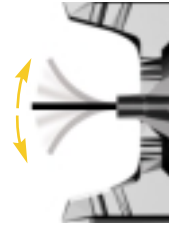

Flexible Electrode

Extra durable SnapBack™ Electrode provides better alignment for a consistent, high-quality finish.



NEW Air Cap design

The indexing system makes handling easier and assures a consistent spray pattern.

Let's make things **LIGHT** and **EASY**

All PRO Xs electrostatic guns are based on Graco's internal power supply technology. Air spray or Air-Assisted airless, hand or automatic - PRO Xs combines the benefits of electrostatic material savings with light weight.

PRO XS FEATURES AND BENEFITS



Voltage/Current Display

The Smart Display™ at the back of the gun for online control of the application set-up.



Select Comfort™ Handle

Smooth curved handle and optional grip sizes improve operator comfort and reduce fatigue.



Air-Powered Gun

AP2™ technology makes installation simple without electrical connections, using only air to generate electrostatic power.

KEY MATERIALS

Enamels
Epoxies
Urethanes
Alkyds
1K & 2K materials

KEY INDUSTRIES

Aerospace
Auto Assembly
Auto Feeder
Bus
Farm & Construction
General Metal
Rail Car
Truck

Choose PRO Xs for:

MATERIAL SAVINGS

Upgrade from air spray and HVLP or change over to electrostatic Air-Assisted airless technology to reduce VOC emissions and save material.

BETTER FINISH

Superb overall finish and when upgrading from HVLP, get better finish quality and faster production speeds.

OPERATOR COMFORT

Reduce fatigue and improve comfort.

TIME SAVINGS

Attach fluid and air connections and you're ready to spray in minutes!

PRO Xs2 The Entry Level Gun



PRO Xs2

This gun is taking your finishing operation to a tougher quality level, at a price point you never expected of an electrostatic air spray gun.

FEATURES INCLUDE:

- Size and weight, comparable to a conventional air spray or HVLP gun.
- Patent pending Power Points™ design to optimize material savings at a lower voltage.
- Electrostatic material savings at a minimum investment.
- Quick return-on-investment.
- A gun to meet European VOC legislation.
- 3-year warranty on power supply, barrel and handle.
- Operator will be satisfied with overall balance.

PERFORMANCE

Maximize your performance with the Graco PRO Xs2 electrostatic gun:

- Upgrade from air spray, or HVLP technologies.
- Conventional air spray gun users can double their material savings.
- Achieve the finish quality and production speed of air spray.



PRO Xs guns are comparable in size, feel and weight to Graco's conventional Delta Spray® guns.

Once in your **HANDS**, you will



**AIR-POWERED
GUN**



**EXTREMELY
LIGHTWEIGHT
GUN**



**POWER
POINTS™**



**FLEXIBLE
ELECTRODE**



**LIGHT
TRIGGER PULL**

Simplicity is the Key

EASY INSTALLATION

- Quick and easy integration into your current set-up saves time and money.
- PRO Xs installation features:
 - No voltage cable needed.
 - No electrical connections needed.
 - No power supply located outside the hazardous area.
- Connect the grounded air hose to the air line and spray!

TYPICAL PRO Xs EX-PROOF INSTALLATION

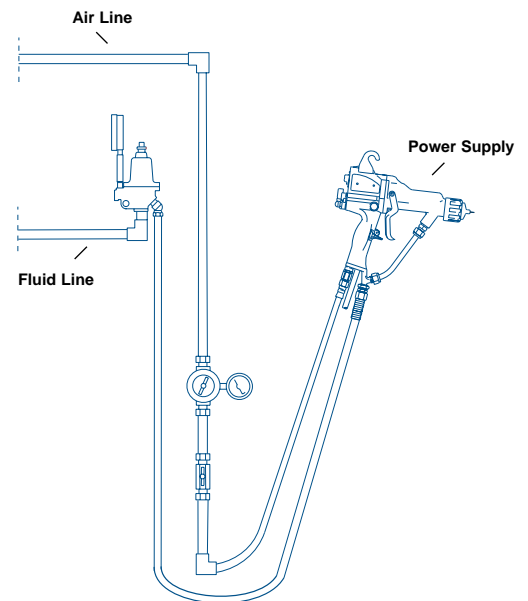

TYPICAL APPLICATIONS

- General metal finishing, e.g. parts with difficult shapes.
- Trailer manufacturers, e.g. trailer top frame construction.
- Metal furniture and fixtures.
- Truck cabs, bus.
- Aircraft decorative paintings and small production parts.
- Wood chairs touch-up and small parts with difficult shapes.



not want to let it go!



INDEXING
AIR CAP



SELECT COMFORT™
HANDLE



OPTIONAL
HAND GRIP SIZES



INTEGRAL
AIR SWIVEL



REPLACEABLE
HOOK

PRO™ Xs





PRO Xs Electrostatic Spray Guns

SMART! VERSION

Voltage and current display at the rear of the gun allows online control of your application set-up. Adjustable voltage for flexibility with materials and applications.



BASIC VERSION

This version comes with an electrostatic indicator light. Green shows when electrostatic is on.

PRO Xs3 smart or basic

PRO Xs3 takes electrostatic finishing to unexpected material savings, ergonomics and finish quality. The durability is what you've come to expect from Graco.

FEATURES INCLUDE:

- 60 Kv voltage output for standard, high conductivity or waterborne coatings.
- Superb finish quality.
- Excellent material savings at an optimal gun size.



PRO Xs4 smart or basic

PRO Xs4 provides material savings and durability with a low cost of ownership, along with a lightweight, comfortable design to reduce operator fatigue.

FEATURES INCLUDE:

- Superb finish quality.
- Good material savings for fast return-on-investment using air spray technology.
- Reduced cost of ownership.



AIR-POWERED GUN



EXTREMELY LEIGHTWEIGHT GUN



SMART™ DISPLAY



FLEXIBLE ELECTRODE



LIGHT TRIGGER PULL

Extremely Lightweight 85 kV Gun

PRO Xs4 Air-Assisted *smart or basic*

PRO Xs4 AA's lightweight, comfortable design reduces operator fatigue with excellent transfer efficiency.

SMART!

BASIC



FEATURES INCLUDE:

- Superb finish quality.
- Good material savings for quickest return-on-investment using air-assisted technology.
- Meets fast production speed requirements.
- Round spray kit and nozzles available.



PRO Auto Xs

PRO Auto Xs guns offer excellent material savings, with the added benefit of easy modular installation.

FEATURES INCLUDE:

- Air Spray model - Available for standard, high conductivity or waterborne coatings.
- Air-Assisted model – Available for standard coatings.
- Superb finish quality.
- Easy installation with AP2 air-powered design.
- Modular manifold design for quick service.
- With connecting gun to a display via fibre optic cable, guns voltage/current output can be indicated.



INDEXING
AIR CAP



SELECT COMFORT™
HANDLE



OPTIONAL
HAND GRIPS
SIZES



INTEGRAL
AIR SWIVEL



REPLACEABLE
HOOK

Developments at a Glance

BETTER FINISH

New gun front-end design, the Finishing Touch™, includes:

Indexing Air Cap

Easy to align for consistent spraying.

Flexible Electrode

Durable SnapBack™ Electrode for longer life and better alignment for consistency.

New Air Cap Design

Improved consistency and uniform alignment. More resistant to breakage due to new material construction.

DURABILITY

Turbine and Bearings

Improved material compatibility for longer life.

Barrel

Wider threads at air cap for improved durability and longer life.

Replaceable Hook

Saves money - no need to replace the whole barrel.

Solvent Resistance

Overall improved design for better material compatibility.

OPERATOR COMFORT

Select Comfort™ Grip

Maximizes comfort for long hours of spraying.

Optional Hand Grips

Customizes the handle to accommodate different hand sizes.

Light Trigger Pull

Helps to reduce fatigue.

Integral Air Swivel

Provides maximum flexibility.

Balance

Best overall balance for operator satisfaction.

SAVINGS

Material Savings

Less paint wasted.

Quick and Easy Installation

Easy installation without electrical connections saves time and money.

Low Cost of Ownership

Reduced time to service, less maintenance.

BENEFITS you can count on !

Electrostatic Performance

Higher voltage up to 35% in actual spraying range, improving material savings.

3-Year Warranty

Includes power supply, barrel and handle.

Approvals

Meets FM, CENELEC, CSA, and CE approvals.

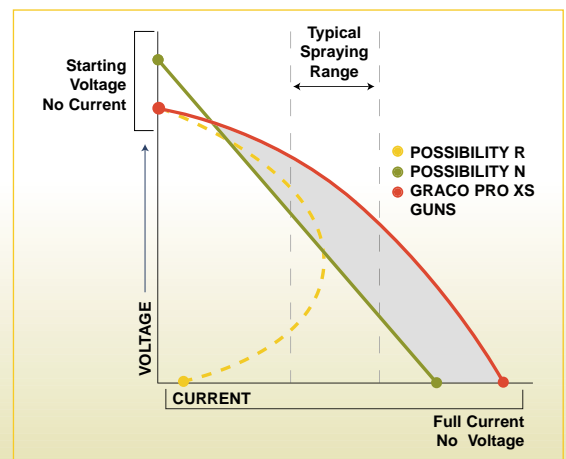

Typical load lines of electrostatic guns

Maximum Savings!

Return-on-Investment

The chart (right) typically shows how your savings increase as you move up the PRO Xs line. Use the analysis tools below to see how much you can save with Graco PRO Xs Electrostatic Guns.

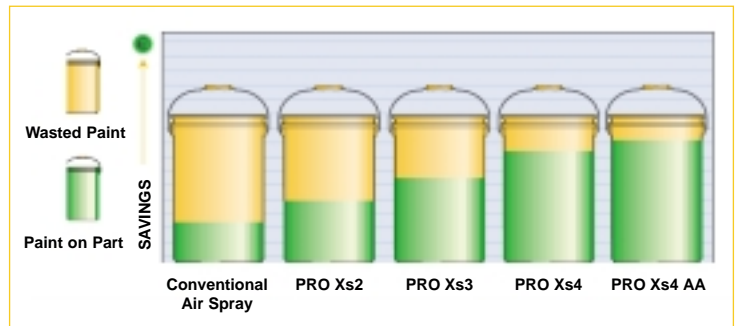

Reduce Operating Costs

BY REPLACING CONVENTIONAL AIR SPRAY AND HVLP GUNS.

	TYPICAL	CALCULATE YOUR OWN
Paint price per litre	€ 4	<input type="text"/>
	X	X
Litre used per day <i>(Typical 20 litre/day)</i>	20	<input type="text"/>
	X	X
Business days per year	220	220
Typical Savings <i>(see below)</i>	X	X
Air Spray		
PRO Xs 2 20% Savings	20%	<input type="text"/>
PRO Xs 3 40% Savings		
PRO Xs 4 60% Savings		
PRO Xs 4 AA 65% Savings		
HVLP		
PRO Xs 2 10% Savings		
PRO Xs 3 30% Savings		
PRO Xs 4 50% Savings		
PRO Xs 4 AA 55% Savings		
Annual Savings	€3520*	<input type="text"/>

**PRO Xs2 pays for itself in less than 6 months!*

ABOUT GRACO

PROVEN QUALITY. LEADING TECHNOLOGY.

Founded in 1926, Graco is a world leader in fluid handling systems and components. Graco products move, measure, control, dispense and apply a wide range of fluids and viscous materials used in vehicle lubrication, commercial and industrial settings.

The Company's success is based on its unwavering commitment to technical excellence, world-class manufacturing and unparalleled customer service. Working closely with specialized distributors, Graco offers systems, products and technology which set the quality standards in a wide range of fluid handling applications including spray finishing and paint circulation, lubrication, sealants and adhesives along with power application equipment for the contractor industry. Graco's ongoing investment in fluid management and control will continue to provide innovative solutions to a diverse global market.

GRACO HEADQUARTERS

L'AMERICAS

MINNESOTA

Worldwide Headquarters
Graco Inc.
88-11th Avenue N.E.
Minneapolis, MN 55413

MAILING ADDRESS

P.O. Box 1441
Minneapolis, MN 55440-1441
Tel 612 623-6000
Fax 612 623-6777

MICHIGAN

Automotive Headquarters
and Sales Office
47800 Halyard Drive
Plymouth, MI 48170
Tel 734 416-3400
Fax 734 416-3441

EUROPE

BELGIUM

European Headquarters
Graco N.V.
Industrieterrein - Oude Bunders
Slakweidestraat 31
3630 Maasmechelen, Belgium
Tél 32 89 770 700
Fax 32 89 770 777

GERMANY

Graco Verfahrenstechnik GmbH
Duisburger Straße 7
D-33647 Bielefeld, Germany

ASIA PACIFIC

JAPAN

Graco K.K.
1-27-12 Hayabuchi
Tsuzuki-ku
Yokohama City, Japan 2240025
Tel 81 45 593 7300
Fax 81 45 593 7301

CHINA

Graco Hong Kong Ltd.
Representative Office, Room 1809,
No. 509 Cao Bao Road
New Cao He Jing Tower
Shanghai, P.R.China 200233
Tel 86 21 649 50088
Fax 86 21 649 50077

KOREA

Graco Korea Inc.
3rd Fl., Doorim Bldg.
164-21 Poi-Dong,
Kangnam-Ku
Seoul, Korea 135-260
Tel 82 2 575-8901
Fax 82 2 571-9422

Graco is registered to I.S. EN ISO 9001.



GRACO N.V.
Industrieterrein Oude Bunders
Slakweidestraat 31 • B-3630 Maasmechelen
Tel: +32 (89) 770 700 • Fax: +32 (89) 770 777
www.graco.com (US) • www.graco.be (Europe)

ACCESSORIES INFORMATION

AUTOMATIC Xs GUNS

224117 E/S Display Module

Receives fibre optic transmission from the PRO Auto Xs gun and displays the gun's output voltage and current. Mounts in a standard 19 in. DIN rack. Refer to Instruction Manual 308265.

Fibre Optic Cable Assembly

For connection between gun manifold and display module or between bulkhead connector and display module. Use only with 224117 display. See Instruction Manual 308265.

Part No.	Length
224682	7.6 m (25 ft.)
224684	15 m (50 ft.)
224686	30.5 m (100 ft.)

235301 Power Supply

Used to supply low voltage DC power to 224117 E/S Display Module. Refer to Instruction Manual 308265.

189762 Remote Voltage Display

Battery-operated meter displays actual spraying voltage. Remote mount outside hazardous area. Connects to gun via fibre optic cable. Refer to Instruction Manual 308265.

Fibre Optic Cable Assembly

For connection between gun manifold and display module (189762) or between gun manifold and bulkhead connector. Refer to Instruction Manual 308265.

Part No.	Length
224672	7.6 m (25 ft.)
224674	15 m (50 ft.)
224676	30.5 m (100 ft.)

kV Display Kit

- 236917 with 7.6 m (25 ft.) fibre optic cable
 - 236919 with 15 m (50 ft.) fibre optic cable
 - 236921 with 30.5 m (100 ft.) fibre optic cable
- Includes remote voltage display (189762)

236853 Dump Valve

Mounts directly to manifold for faster flushing and colour changes.

236854 Fluid Regulator

Air-piloted fluid regulator mounts at manifold for precise fluid control.

245324 PRO Auto Xs High Conductivity Conversion Kit

For converting a PRO Auto Xs standard coating gun to a high conductivity PRO Auto Xs spray gun.

TEST EQUIPMENT

Paint Resistivity Meter (used together)

- 722886 Meter
- 722860 Probe

236003 High Voltage Probe and Meter

Complete assembly includes high voltage probe, meter and ground wire.

241079 Megohmmeter

Used to check gun resistance and part grounding.

245277 Test Equipment Kit

Includes 236003 High Voltage Probe, 245278 PRO Xs Cartridge and Alternator Test Fixture, 189351 Alignment Sleeve, carrying case and instruction manual.

PRO Xs Electrostatic Guns Product Information

PRO Xs MANUAL GUN TECHNICAL SPECIFICATIONS

	PRO Xs2	PRO Xs3	PRO Xs4	PRO Xs4 AA
Max. working fluid pressure	7 bar (0.7 MPa, 100 psi)	7 bar (0.7 MPa, 100 psi)	7 bar (0.7 MPa, 100 psi)	207 bar (20.7 MPa, 3000 psi)
Max. working air pressure	7 bar (0.7 MPa, 100 psi)	7 bar (0.7 MPa, 100 psi)	7 bar (0.7 MPa, 100 psi)	7 bar (0.7 MPa, 100 psi)
Gun weight	667 g (23.5 oz.)	711 g (25.1 oz.)	788 g (27.8 oz.)	825 g (29.1 oz.)
Gun length	21.8 cm (8.6 in.)	24.6 cm (9.7 in.)	28.2 cm (11.1 in.)	29.0 cm (11.4 in.)
Recommended paint resistivity range	7 to 150 megohm-cm	7 to ∞ megohm-cm	25 to ∞ megohm-cm	7 to ∞ megohm-cm
Max. voltage output	Power Point design	60 kilovolts	85 kilovolts	85 kilovolts
Max. fluid working temp.	48.8°C (120°F)	48.8°C (120°F)	48.8°C (120°F)	48.8°C (120°F)
Air inlet	1/4 npsm (l.h.)	1/4 npsm (l.h.)	1/4 npsm (l.h.)	1/4 npsm (l.h.)
Fluid inlet	3/8-18 npsm (R 3/8-19) compound thread	3/8-18 npsm (R 3/8-19) compound thread	3/8-18 npsm (R 3/8-19) compound thread	1/4-18 npsm
Wetted parts	polyethylene, SST, nylon, acetal, Teflon, UHMWPE, fluoroelastomer, PEEK	polyethylene, SST, nylon, acetal, Teflon, UHMWPE, fluoroelastomer, PEEK	polyethylene, SST, nylon, acetal, Teflon, UHMWPE, fluoroelastomer, PEEK	SST, nylon, PEEK, UHMWPE, carbide, acetal
Noise data*				
Sound pressure	87.0 dBA	87.0 dBA	87.0 dBA	95.0 dBA
Sound power	90.4 dBA	90.4 dBA	90.4 dBA	99.7 dBA
Instruction manual	309294	309294 309293	309294	309296

*All readings were taken at 40 psi (2.8 bar, 0.3 MPa). Sound pressure was tested to CAGI-PNUEROP-1969 and sound power to ISO 3744-1981.

UHMWPE - Ultra-High Molecular Weight Polyethylene



©2001 Graco Inc. Form No. 300-542 E Rev.A 08/01 Printed in Europe.

All data in this document is based on the latest product information available at the time of publication.

Graco reserves the right to make changes at any time without notice.

Graco N.V. - Industrieterrein Oude Bunders - Slakweidestraat 31 - B-3630 Maasmechelen

Tel: +32 (89) 770 700 - Fax: +32 (89) 770 777 - Http://www.graco.com (US) - www.graco.be (Europe)

PRO Xs AUTOMATIC GUN TECHNICAL SPECIFICATIONS

	PRO Auto Xs	PRO Auto Xs AA
Max. working fluid pressure	7 bar (0.7 MPa, 100 psi)	207 bar (20.7 MPa, 3000 psi)
Max. working air pressure	7 bar (0.7 MPa, 100 psi)	7 bar (0.7 MPa, 100 psi)
Gun weight	1.60 kg (3.52 lb.)	1.60 kg (3.52 lb.)
Gun length	31.1 cm (12.25 in.)	31.1 cm (12.25 in.)
Voltage output	85 kilovolts	85 kilovolts
Air Inlet (fittings are included with gun)		
Atomizing air	5/32 in. OD nylon tube	5/32 in. OD nylon tube
Fan air	5/32 in. OD nylon tube	N/A
Cylinder pilot	1/4 in. OD nylon tube	1/4 in. OD nylon tube
Hi-lo voltage selector	1/4 in. OD nylon tube	1/4 in. OD nylon tube
Turbine air	1/4 npsm (l.h.)	1/4 npsm (l.h.)
Fluid inlet	1/4-18.6 npsm(m)	1/4-18 npsm
Wetted parts	SST, nylon, PEEK, UHMWPE, acetal	SST, nylon, PEEK, UHMWPE, carbide, acetal
Instruction manual	309297	309298

ORDERING INFORMATION

244399 PRO Xs2

Gun includes 1.5 mm nozzle, 197477 air cap. Grounded air hose must be ordered separately.



244399

244400 PRO Xs3 for Standard Coatings

Gun includes 1.5 mm nozzle and 197477 air cap. Grounded air hose must be ordered separately.

244579 PRO Xs3 Smart Gun for Standard Coatings

Includes Smart Display™ showing voltage and current at the gun, adjustable voltage, 1.5 mm nozzle and 197477 air cap. Grounded air hose must be ordered separately.



244579

244575 PRO Xs3 High Conductivity Coatings

Gun includes 1.5 mm nozzle and 197477 air cap. Grounded air hose must be ordered separately.

244576 PRO Xs3 Smart Gun for High Conductivity Coatings

Includes Smart Display showing voltage and current at the gun, adjustable voltage, 1.5 mm nozzle and 197477 air cap. Grounded air hose must be ordered separately.



244575

244581 PRO Xs3 for Waterborne Coatings

Gun includes 1.5 mm nozzle and 197477 air cap. Waterborne fluid hose must be ordered separately (includes fluid tube and gun fittings). Grounded air hose must be ordered separately.

ORDERING INFORMATION, CONTINUED

244582 PRO Xs3 Smart Gun for Waterborne Coatings

Includes Smart Display showing voltage and current at the gun, adjustable voltage, 1.5 mm nozzle and 197477 air cap. Waterborne fluid hose must be ordered separately (includes fluid tube and gun fittings). Grounded air hose must be ordered separately.



244582

245301 Waterborne PRO Xs3 Gun Kit

PRO Xs3 gun with 7.6 m (25 ft.) waterborne fluid hose. Grounded air hose must be ordered separately.

245305 Waterborne PRO Xs3 Gun Kit

PRO Xs3 Smart gun with 7.6 m (25 ft.) waterborne fluid hose. Grounded air hose must be ordered separately.

244401 PRO Xs4, Standard

Gun includes 1.5 mm nozzle and 197477 air cap. Grounded air hose must be ordered separately.



244401

244580 PRO Xs4, Smart

Includes Smart Display showing voltage and current at the gun, adjustable voltage, 1.5 mm nozzle and 197477 air cap. Grounded air hose must be ordered separately.

244572 PRO Xs4, Air-Assisted, Standard

Includes tip of choice when ordering. Grounded air hose must be ordered separately.

244573 PRO Xs4, Air-Assisted, Smart

Includes Smart Display showing voltage and current at the gun, adjustable voltage and tip of choice when ordering. Grounded air hose must be ordered separately.



244573

244589 PRO Auto Xs for Standard Coatings

Includes gun shroud, mounting bracket, gun manifold and gun with 1.5 mm fluid nozzle and 197477 air cap. Grounded air hose must be ordered separately.



244589

244590 PRO Auto Xs for High Conductivity Coatings

Includes gun shroud, mounting bracket, gun manifold and gun with 1.5 mm fluid nozzle and 197477 air cap. Grounded air hose must be ordered separately.

244591 PRO Auto Xs for Waterborne Coatings

Includes gun shroud, mounting bracket, gun manifold and gun with 1.5 mm fluid nozzle and 197477 air cap. Waterborne fluid hose must be ordered separately (includes fluid tube and gun fittings). Grounded air hose must be ordered separately.



244591

244592 PRO Auto Xs AA

Includes gun, shroud, mounting brackets, gun manifold and gun with tip of choice. Grounded air hose must be ordered separately.



244592

ACCESSORIES INFORMATION

Grounded Air Hoses (required for use)

Length	Air Flex™	Standard	Waterborne*
1.8 m (6 ft.)	244963	223068	235068
4.6 m (15 ft.)	244964	223069	235069
7.6 m (25 ft.)	244965	223070	235070
11 m (36 ft.)	244966	223071	235071
15 m (50 ft.)	244967	223072	235072
23 m (75 ft.)	244968	223073	235073
30.5 m (100 ft.)	244969	223074	235074

Air Flex

EPDM rubber core and cover for extra flexibility.

Standard

Modified semi-conductive polyamide core, urethane cover for added durability.

*Waterborne (required for waterborne applications)

Conductive SST wire braid for grounding. Polyurethane tube and cover.

185493 Air Hose Adapter Nipple

Allows for the connection of multiple air hoses as needed for the special grounded PRO air hoses. 1/4 npsm (L.H.) x 1/4 npsm.

112534 Air Quick Disconnect/Swivel

Swiveling air quick disconnect designed to replace the standard air swivel fitting in the gun handle.

244914 Gun Covers (box of 10)

For PRO Xs2 gun.

244915 Gun Covers (set of 10)

For PRO Xs3, PRO Xs4 and PRO Xs4 AA guns.

239945 Gun Covers (box of 10)

For PRO Auto Xs guns.

Select Comfort Grips™

Snap-on grips to increase the handle size to reduce operator fatigue.

245263 Medium Grip Kit

245264 Large Grip Kit

223688 Turbine Alternator Bearing Repair Kit

105749 Cleaning Brush

AIR SPRAY PRO Xs GUNS

Fluid Nozzles

Part no.	Size
197263	0.75 mm (0.030 in.)
197264	1.0 mm (0.042 in.)
197265	1.2 mm (0.047 in.)
197266	1.5 mm (0.055 in.)
197267	1.8 mm (0.070 in.)
197268	2.0 mm (0.080 in.)

ACCESSORIES INFORMATION, CONTINUED

AIR SPRAY PRO Xs GUNS, CONTINUED

Air Caps

Part no.	Type	Pattern Width
197477	Round end	381-431.8 mm (15-17 in.)
197478	Low flow	355.6-406.4 mm (14-16 in.)
197479	Tapered end	444.5-495.3 mm (17.5-19.5 in.)
197480	Large pattern	406.4-457.2 mm (16-18 in.)
197481	With 2.0 nozzle only	406.4-457.2 mm (16-18 in.)

Round Pattern Kits

Consists of fluid tip, diffuser and air cap.

245217 102-152 mm (4-6 in.) diameter

245219 203-254 mm (8-10 in.) diameter

Fluid Hose

215637 1/4 in. ID x 7.6 m (25 ft.)

215638 1/4 in. ID x 15.2 m (50 ft.)

244912 Push/Pull Valve

For quick change of fan size.

235300 Gun Mounting Bracket

Allows gun to hang with barrel in a downward orientation to prevent material from getting into the air passages.

244911 Fluid Seal Repair Kit

244916 Four Finger Trigger Kit

Allows the conversion of PRO Xs3 and PRO Xs4 guns to be used with a four-finger trigger.

244919 High Conductivity Kit

Allows standard coating PRO Xs3 guns to effectively spray high conductivity coatings.

244781 Air Seal Repair Kit (manual guns)

245270 Gun Washer Kit

Used to convert Graco gun washers so they can clean PRO Xs air spray guns.

245252 Waterborne Fluid Hose

7.6 m (25 ft.) fluid hose. Used only with PRO Xs3 waterborne guns.

244731 0.95 l (1 Quart) Remote Pressure Cup

Includes air regulators for both gun atomization and supply air to the pressure cup.

244732 1.90 l (2 Quart) Remote Pressure Cup

Includes air regulators for both gun atomization and supply air to the pressure cup.

198405 Gun Flush Box

Used to convert existing gun flush boxes to hold PRO Xs3 and Xs4 models guns

ACCESSORIES INFORMATION, CONTINUED

Tip Selection Chart For PRO Xs4 AA and PRO Auto Xs AA Spray Guns

Orifice Size in. (mm)	Fan Width at 10 in. (260 mm) in. (mm)	Part No.
0.007 (0.178)	2-4 (50-100)	GG3107
	4-6 (100-150)	GG3207
	6-8 (150-200)	GG3307
0.009 (0.229)	4-6 (100-150)	GG3209
	6-8 (150-200)	GG3309
	8-10 (200-250)	GG3409
0.011 (0.279)	4-6 (100-150)	GG3211
	6-8 (150-200)	GG3311
	8-10 (200-250)	GG3411
	10-12 (250-300)	GG3511
	12-14 (300-350)	GG3611
0.013 (0.330)	4-6 (100-150)	GG3213
	6-8 (150-200)	GG3313
	8-10 (200-250)	GG3413
	10-12 (250-300)	GG3513
	12-14 (300-350)	GG3613
0.015 (0.381)	4-6 (100-150)	GG3215
	6-8 (150-200)	GG3315
	8-10 (200-250)	GG3415
	10-12 (250-300)	GG3515
	12-14 (300-350)	GG3615
0.017 (0.432)	4-6 (100-150)	GG3217
	6-8 (150-200)	GG3317
	8-10 (200-250)	GG3417
	10-12 (250-300)	GG3517
	12-14 (300-350)	GG3617
0.019 (0.483)	6-8 (150-200)	GG3319
	8-10 (200-250)	GG3419
	10-12 (250-300)	GG3519
	12-14 (300-350)	GG3619
	14-16 (350-400)	GG3719
0.021 (0.533)	8-10 (200-250)	GG3421
	10-12 (250-300)	GG3521
	12-14 (300-350)	GG3621
	14-16 (350-400)	GG3721
	16-18 (400-450)	GG3821
0.023 (0.584)	8-10 (200-250)	GG3423
	10-12 (250-300)	GG3523
	12-14 (300-350)	GG3623
	14-16 (350-400)	GG3723
	16-18 (400-450)	GG3823
0.025 (0.635)	8-10 (200-250)	GG3425
	10-12 (250-300)	GG3525
	12-14 (300-350)	GG3625
	14-16 (350-400)	GG3725
	16-18 (400-450)	GG3825

ACCESSORIES INFORMATION, CONTINUED

AIR-ASSISTED PRO Xs GUNS

245282 PRO Xs4 AA Round Spray Kit (manual guns)
Round spray provides a higher level of performance to electrostatic spraying. Includes tip of choice.

245298 PRO Auto Xs AA Round Spray Kit
Round spray provides a higher level of performance to electrostatic spraying. Includes tip of choice.

Part No.	Pattern Width	Flow Rate at 40 bar	at 80 bar
236836	229 mm (9 in.)	120 cc/min.	170 cc/min.
236837	254 mm (10 in.)	150 cc/min.	220 cc/min.
236838	254 mm (10 in.)	160 cc/min.	230 cc/min.
236839	356 mm (14 in.)	230 cc/min.	330 cc/min.
236840	330 mm (13 in.)	270 cc/min.	420 cc/min.
236841	305 mm (12 in.)	350 cc/min.	530 cc/min.
236842	279 mm (11 in.)	480 cc/min.	700 cc/min.

244917 Electrode Replacement Kit
Includes 5 electrodes.

115898 Fluid Swivel

238563 In-Line Fluid Filter, 60 mesh (3 pack)
To replace the 100 mesh filter that is included with the gun.

244834 Integral Air Swivel with Left Handed Threads

Air Whipphose

Grounded air hose for extra flexibility.

236130	0.9 m (3 ft.)
236131	1.8 m (6 ft.)

Fluid Whip Hose

Maximum working pressure: 207 bar (20.7 MPa, 3000 psi)
ID: 1/8 in. (3.2 mm). Thread size: 1/4 npsm(f) x 1/4 npt(m).

236134	Length: 0.9 m (3 ft.)
236135	Length: 1.8 m (6 ft.)

Fluid Hose

223540	1/4 in. ID x 7.6 m (25 ft.)
223541	1/4 in. ID x 15.2 m (50 ft.)

244913 E/S Always on Kit

Replaces inlet fitting with ball valve to shut air off during flushing.
Converts ES on/off lever to always ON condition.

244781 Air Seal Repair Kit (manual guns)

245271 Gun Washer Kit

Used to convert Graco gun washers to clean PRO Xs air-assisted guns.

198405 Gun Flush Box

Used to convert existing gun flush boxes to hold PRO Xs3 and Xs4 models guns