

Delta Spray® XT Gun

310692 rev.G

For Airspray, HVLP, and Compliant guns with pressure, siphon, and gravity feeds.

*300 psi (2.1 MPa, 21bar) Maximum Working Fluid Pressure
100 psi (0.7 MPa, 7 bar) Maximum Working Air Pressure*



Important Safety Instructions

Read warnings and instructions in this manual.
Save these instructions.

See page 4 for selection list of models.

EU Patent No. 0885658

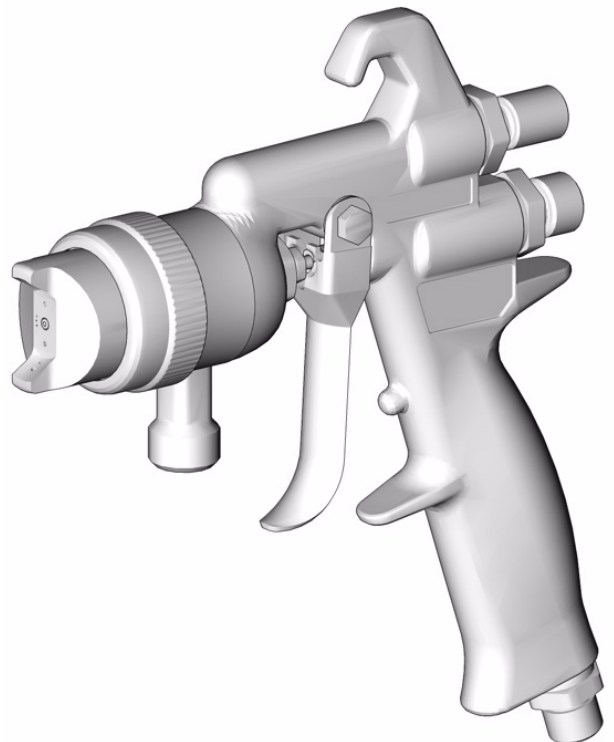

ti4819

PROVEN QUALITY. LEADING TECHNOLOGY.

Contents

Related Manuals 2
 Manual Conventions 2
 Warnings 3
 Selection Charts 4
 Gun Selection 6
 Air Caps 6
 Nozzle, Needle, and Tip Selection 7
 Installation 8
 Setup 9

Operation 13
 Daily Gun Maintenance 14
 Troubleshooting 18
 Service 19
 Parts 26
 Accessories 30
 Technical Data 33
 Graco Standard Warranty 34
 Graco Information 34

Related Manuals

The Delta Spray XT manual is also available in the following languages. See chart below for specific language and part number.

French	310779
German	310780
Italian	310781
Spanish	310782
Finnish	310783
Danish	310784

Norwegian	310785
Swedish	310786
Dutch	310787
Japanese	310788
Korean	310789
Chinese	310790

Manual Conventions

 **WARNING**



WARNING indicates a potentially hazardous situation which, if not avoided, could result in death or serious injury.

Warnings included in instructions generally have a symbol indicating the hazard. Follow the instructions and read the hazard section on warning page 3 for additional information.

CAUTION

CAUTION indicates a potentially hazardous situation which, if not avoided, may result in property damage or destruction of equipment.





Note



A note indicates additional helpful information.

Warnings

The following warnings include general safety information for this equipment. More specific warnings are included in the text where applicable.

 WARNING	
	<p>FIRE AND EXPLOSION HAZARD - FE CED/IND General</p> <p>Flammable fumes, such as solvent and paint fumes, in work area can ignite or explode. To help prevent fire and explosion:</p> <ul style="list-style-type: none"> • Use equipment only in well ventilated area. • Eliminate all ignition sources; such as pilot lights, cigarettes, portable electric lamps, and plastic drop cloths (potential static arc). • Keep work area free of debris, including solvent, rags and gasoline. • Do not plug or unplug power cords, or turn power or light switches on or off when flammable fumes are present. • Ground equipment and conductive objects in work area. See Grounding instructions. • Use only grounded hoses. • Hold gun firmly to side of grounded pail when triggering into pail. • If there is static sparking or you feel a shock, stop operation immediately. Do not use equipment until you identify and correct the problem.
	<p>PRESSURIZED EQUIPMENT HAZARD</p> <p>Fluid from the gun/dispense valve, leaks, or ruptured components can splash in the eyes or on skin and cause serious injury.</p> <ul style="list-style-type: none"> • Follow Pressure Relief Procedure in this manual, when you stop spraying and before cleaning, checking, or servicing equipment. • Tighten all fluid connections before operating the equipment. • Check hoses, tubes, and couplings daily. Replace worn or damaged parts immediately.
	<p>EQUIPMENT MISUSE HAZARD</p> <p>Misuse can cause death or serious injury.</p> <ul style="list-style-type: none"> • Do not exceed the maximum working pressure or temperature rating of the lowest rated system component. See Technical Data in all equipment manuals. • Use fluids and solvents that are compatible with equipment wetted parts. See Technical Data in all equipment manuals. Read fluid and solvent manufacturer's warnings. • Check equipment daily. Repair or replace worn or damaged parts immediately. • Do not alter or modify equipment. • For professional use only. • Use equipment only for its intended purpose. Call your Graco distributor for information. • Route hoses and cables away from traffic areas, sharp edges, moving parts, and hot surfaces. • Do not use hoses to pull equipment. • Comply with all applicable safety regulations.
	<p>TOXIC FLUID OR FUMES HAZARD</p> <p>Toxic fluids or fumes can cause serious injury or death if splashed in the eyes or on skin, inhaled, or swallowed.</p> <ul style="list-style-type: none"> • Read MSDS's to know the specific hazards of the fluids you are using. • Store hazardous fluid in approved containers, and dispose of it according to applicable guidelines.

Selection Charts

Pressure feed spray guns

Orifice Size in. (mm)	HVLP	Compliant	Airspray
.030 (0.75)	234647	234693	234636
.042 (1.0)	234648	234694	234637
.055 (1.4)	234649	234695	234638
.070 (1.8)	234650	234696	234639
.086 (2.2)	234651		234640
.110 (2.8)	234652		234641
.042 (1.0)	234653*		234644*
.055 (1.4)	234654*		234645*
.070 (1.8)	234655*		234646*
.030 (0.75)			249856†
.042 (1.0)			249857†
.055 (1.4)			249858†
.070 (1.8)			249589†

* Guns included with hardened SST needle tips, and nozzles.

† Clear chromate gun body.

Pressure feed spray guns with 1 quart pressure feed cup 239802

Orifice Size in. (mm)	HVLP
.042 (1.0)	234709
.055 (1.4)	234710
.070 (1.8)	234711
.086 (2.2)	234712

Siphon feed spray guns

Orifice Size in. (mm)	Spray Gun Only		Spray Gun with 1 quart SST cup	
	Compliant	Airspray	Compliant	Airspray
.055 (1.4)	234695	234642	234732	234718
.070 (1.8)	234696	234643	234733	234719

Gravity feed spray guns (without gravity cup)

Orifice size in. (mm)	HVLP	Compliant	Airspray
.055 (1.4)	234658	234685	234662
.070 (1.8)	234659	234686	234663

Gravity feed spray guns with 16 oz. gravity cup

Orifice size in. (mm)	HVLP	Compliant	Airspray
.055 (1.4)	234713	234721	234705
.070 (1.8)	234714	234722	234706

Gravity feed spray guns with 3M™ PPS™ gravity cup

Orifice Size in. (mm)	HVLP	Compliant	Airspray
.055 (1.4)	234681	234689	234677
.070 (1.8)	234682	234690	234678

Gun Selection

HVLP Guns

An HVLP gun is a high transfer efficiency gun which limits the air pressure at the aircap to 10 psi maximum. In some areas, an HVLP gun is required for compliance with environmental standards.

Compliant Guns

A compliant gun is a high transfer efficiency gun which has been tested to have a transfer efficiency greater than or equal to HVLP guns. The Graco compliant guns have no restrictions on aircap pressures, but the gun inlet pressure must remain under 29 psi (21 MPa 2.1 bar) to remain in compliance.

Airspray Guns

Excellent atomization and high production rates typically with some reduction in transfer efficiency.

Air Caps

The chart below lists the air caps available for pressure feed, gravity, and siphon feed guns.

Spray Gun	Air Cap ID	Typical Pattern Width* in. (mm)	Gun Feed	Nozzle Orifice in. (mm)	Part Number
HVLP	321	15 (381)	Pressure Feed	.030-.070 (.75-1.8)	234753
HVLP	322	15 (381)	Pressure Feed	.086 (2.2)	234754
HVLP	323	15 (381)	Pressure Feed	.110 (2.8)	234755
HVLP	320	12 (305)	Gravity/Siphon Feed	.030-.070 (.75-1.8)	234752
Compliant	006	11 (279)	All Models	.030-.070 (.75-1.8)	234762
Airspray	315	13 (330)	Pressure Feed	.030-.070 (.75-1.8)	234757
Airspray	318	10 (254)	Pressure Feed	.086 (2.2)	234760
Airspray	319	10 (254)	Pressure Feed	.110 (2.8)	234761
Airspray	317	9 (229)	Gravity/Siphon Feed	.030-.070 (.75-1.8)	234759
Airspray	313	10 (254)	Pressure Feed	.030-.070 (.75-1.8)	234756
Airspray	316	10 (254)	Pressure Feed	.030-.070 (.75-1.8)	234758

* Measured with gun nozzle 8 in. (203 mm) from target surface.

Nozzle, Needle, and Tip Selection

The chart below lists the available nozzle sizes and required fluid needle and nozzles for the Delta Spray XT guns. The HVLP, Compliant, and Airspray guns all use the same nozzle design and fluid needles. When spraying high flow rates and high viscosity materials use the larger nozzle sizes and when spraying light materials or low flow rates, use the smaller nozzle sizes.

Nozzle Orifice in. (mm)	Nozzle	Fluid Needle Assy.	Needle Tip	Needle/Nozzle Kit	Typical Uses	
.030 (.75)	234741	234765	234777	234829	Light Stains	<div style="text-align: center;"> low flow  high flow </div>
.042 (1.0)	234742	234765	234777	234830		
.051 (1.3)	234743	234767	234778	234831	Low Viscosity	
.055 (1.4)	234744	234767	234778	234832		
.059 (1.5)	234745	234767	234778	234833	Medium Viscosity	
.070 (1.8)	234746	234767	234778	234834		
.086 (2.2)	234747	234769	234779	234835	High Viscosity-Adhesives	
.110 (2.8)	234748	234770	234780	234836		
.042 (1.0)	234749	234766	234781*	234774	Nozzle and needle tip made from hardened stainless steel for longer life	
.055 (1.4)	234750	234768	234782*	234775		
.070 (1.8)	234751	234768	234782*	234776		

* Use with shut off spring 110402, see parts page 26.

Installation

Top and bottom feed guns

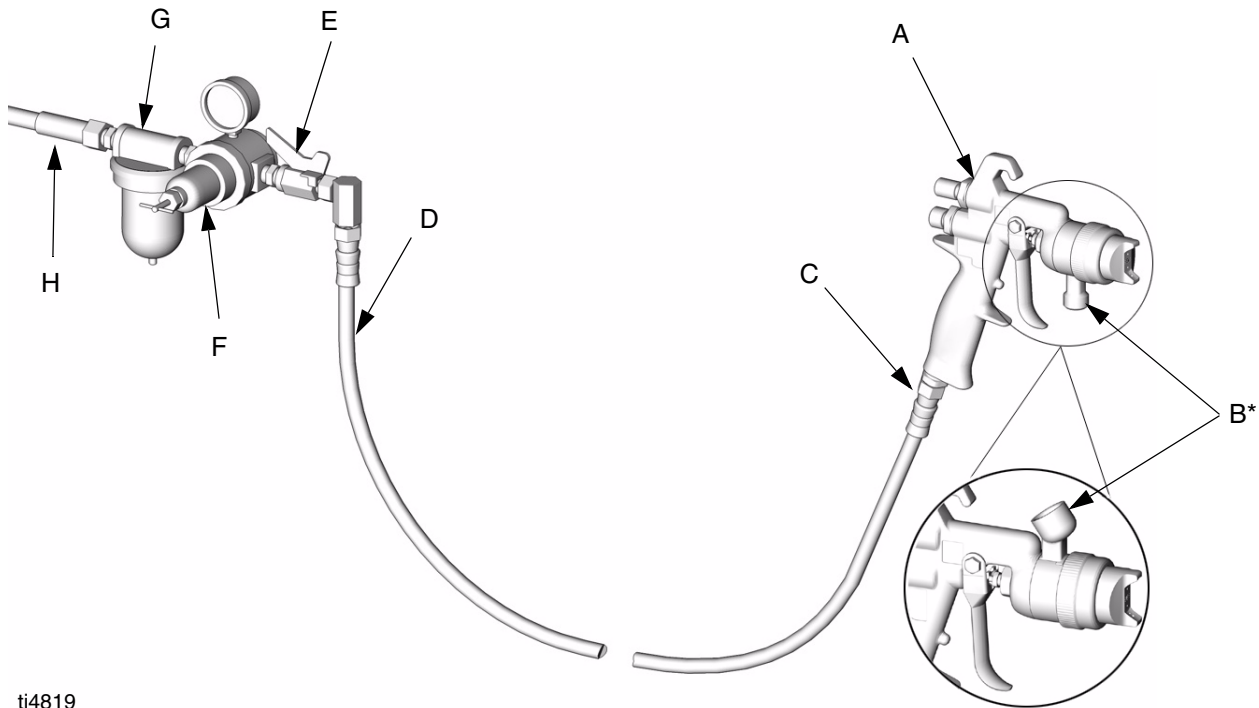

ti4819

FIG. 1

Key:

- A Delta Spray XT Gun
- B Fluid Inlet, 3/8 npsm (R3/8-19)*
- C Air Inlet
- D Air Hose
recommended 5/16 in. (7.9 mm) ID hose
optional 3/8 in. (9.5 mm) ID hose

- E Air Shutoff Valve
- F Air Regulator
- G Air Filter
- H Air Supply Line

*Pressure and siphon feed guns will have bottom feed insert. Gravity feed guns will have a top feed insert.

Setup

Flushing the gun

 Flush the spray gun before putting any paint through the gun.

WARNING



Read warnings, page 3. Follow **Top and bottom feed guns** installation, page 8.

1. To flush the gun, use a solvent that is compatible with paint to be sprayed. Hold a metal part of the gun firmly to a grounded metal pail. Trigger the gun to flush solvent through gun.

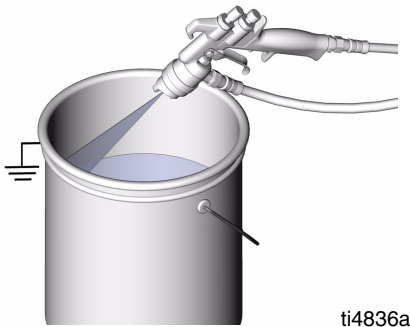

FIG. 2

Connecting the air line

2. Install an air pressure regulator (F). See FIG. 1.

3. Install an air filter (G). See FIG. 1.
4. Use a 5/16 inch (7.9 mm) I.D. air hose to minimize excessive pressure drop in the hose.
5. Connect the air hose (D) to the 1/4 npsm gun air inlet (C).

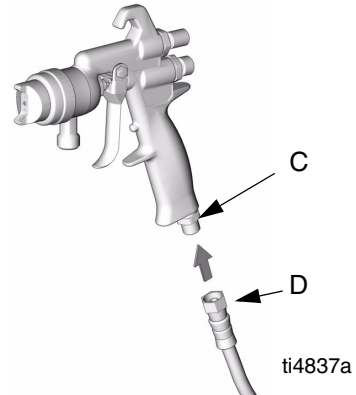

FIG. 3

6. Connect the other end of the air hose (D) to a regulated air supply line.

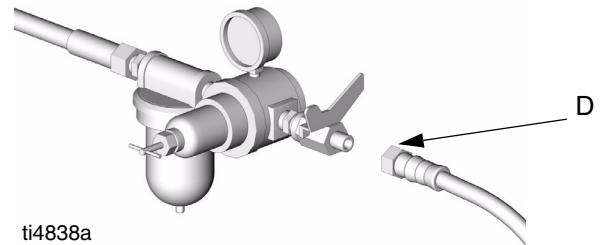

FIG. 4

Connecting the fluid hose

(Pressure feed guns only)

1. To control fluid pressure to the gun, install a fluid regulator on the fluid line.
2. Connect the fluid hose (J) to the gun fluid inlet (B) 3/8-18 npsm [R 3/8-19] compound thread.

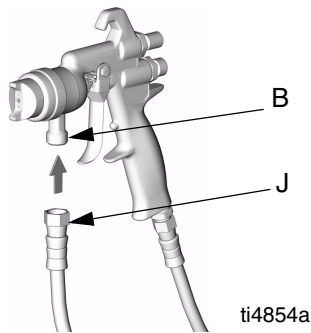

FIG. 5

3. Connect the other end of the fluid hose (J) to a regulated fluid supply line.

Connecting the fluid supply

For packages that include fluid cups, use the following chart for installation instructions.

Cup attachment	Instruction Manual
3M PPS	310693
Gravity Cup	308792
Siphon Cup	308792
Pressure Cups	308791

Positioning the Air Cap

Rotate the air cap as needed to achieve the desired spray pattern direction. To create a round pattern, turn the pattern air off by turning the pattern adjustment knob (25) fully clockwise. See FIG. 7.

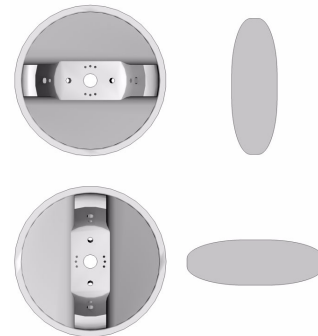
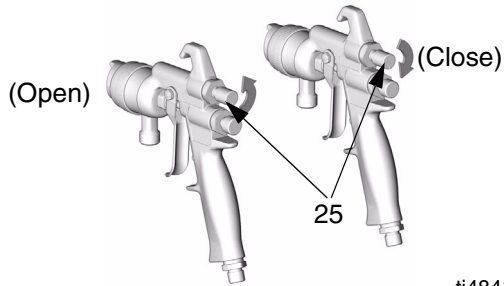

FIG. 6

Adjusting the Spray Pattern

1. To achieve full fan pattern, open the pattern adjustment valve (25) by turning the knob fully counterclockwise.



ti4841a

FIG. 7

2. Trigger gun and adjust gun air pressure:

	Gun Inlet Air Pressure PSI (kpa, bar)	Hose Inlet Air Pressure PSI (kPa, bar) 25 ft 5/16 in. (7.9 mm) ID hose
HVLP Gravity	29 (210, 2.1)	50 (345, 3.4)
HVLP Pressure	40 (280, 2.8)	72 (480, 4.8)
Compliant	29 (210, 2.1)	41 (280, 2.8)
Airspray gravity feed	40 (280, 2.8)	52 (345, 3.4)
Airspray pressure feed	40 (280, 2.8)	56 (410 4.1)

⚠ WARNING

PRESSURIZED EQUIPMENT HAZARD

To avoid injury, never open the fluid adjustment knob (21) beyond the one half turn indicated in step 3 in **Adjusting the Spray Pattern**. If the red band on the knob stem (21) is visible, the knob is not adjusted correctly and could result in serious injury. Repeat step 3 in **Adjusting the Spray Pattern**.

3. To establish the correct fluid flow, turn the fluid adjustment knob (21) counterclockwise until no restriction of the trigger movement is felt, then turn out another half turn. When the knob is turned far enough, the trigger should be able to touch the gun handle when the gun is triggered.

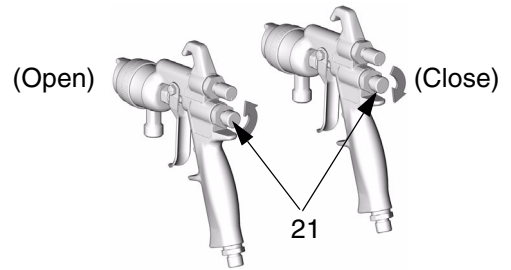

ti4840a

FIG. 8

4. *Pressure feed only:* Adjust fluid pressure to achieve desired fluid flow rate

5. To reduce fluid flow, turn the fluid adjustment knob (21) clockwise.



- If the fluid adjustment knob is turned clockwise all the way, the gun will emit only air.
- If you cannot achieve the correct fluid flow with the fluid adjustment knob, a different sized nozzle may be necessary. For smaller fluid flow, use the next size smaller nozzle. For a larger fluid flow, use the next size larger nozzle.

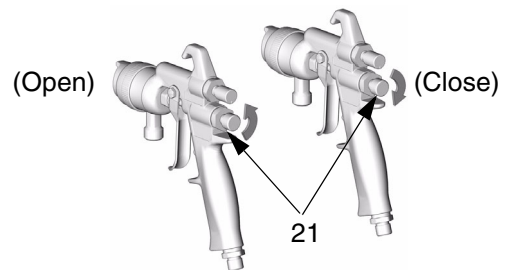

ti4840a

FIG. 9

6. Spray a test pattern. Evaluate the spray pattern size and atomization.

7. To achieve a narrow spray pattern, turn pattern adjustment valve (25) clockwise.

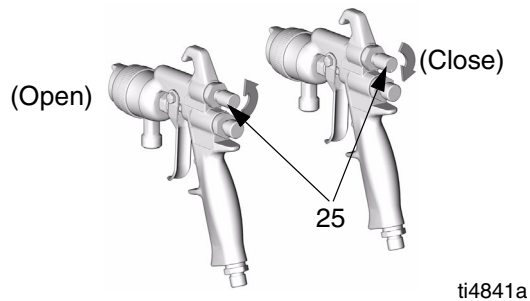

ti4841a

FIG. 10

8. *For HVLP only.* To measure the aircap atomizing pressures, use the accessory aircap verification kit. See Accessories on page 30.
9. To improve atomization, reduce the fluid flow rate. Increasing the air pressure can improve atomization but may result in poor Transfer Efficiency (TE) or non-compliant operation.
- For gravity feed HVLP guns, at 29 psi (200 kPa, 2.0 bar) gun inlet air pressure, the pressure at the aircap will be 10 psi (70 kPa, 0.7 bar).
 - For pressure feed HVLP guns, at 40 psi (280 kPa, 2.8 bar) gun inlet air pressure, the pressure at the air cap will be approximately 10 psi (70 kPa, 0.7 bar).
 - For HVLP guns, local laws may limit the maximum automatic air pressure to 10 psi (70 kPa, 0.7 bar) at the air cap for HVLP compliance. The accessory Air Cap Verification Kit is available to measure the atomizing pressure at the air cap. See Accessories on page 30.
 - For Compliant guns, to maintain compliant operation (TE equal to HVLP) the gun inlet pressure must not exceed 29 psi.

Operation

Pressure Relief Procedure

WARNING



Follow **Pressure Relief Procedure**, page 13 when you stop spraying and before cleaning, checking, servicing, or transporting equipment. Read warnings, page 3.

1. Turn off air and fluid supply.
2. Hold a metal part of the gun firmly to a grounded metal pail. Trigger the gun to relieve pressure.

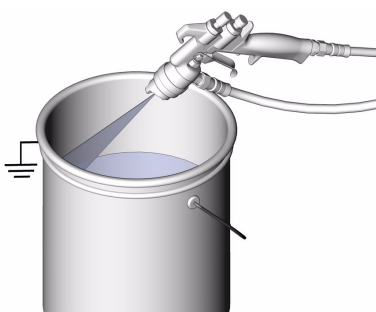

ti4836a

FIG. 11

Applying the Fluid

When using the HVLP spray gun, instead of a conventional airspray gun, you may need to use a slightly slower hand movement and make fewer passes with the gun to coat a part. This is due to the reduced spray velocity produced by lower HVLP air pressures, along with a larger fluid particle size because there is less air to blow off solvents than what is produced by conventional airspray. Take care to avoid runs or sags as you spray.

1. To achieve the best results when applying fluid:
 - Keep the gun perpendicular and 6 to 8 inches (150 to 200 mm) from the object being sprayed.
 - Use smooth, parallel strokes across the surface to be sprayed with 50% overlap.

Incorrect

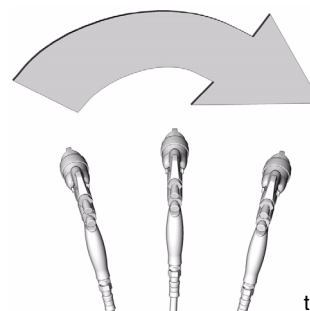

ti4843a

Correct

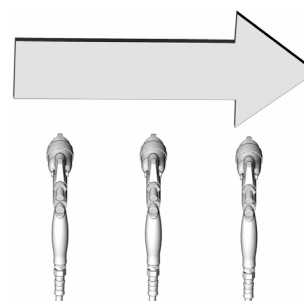

ti4842a

FIG. 12

Daily Gun Maintenance

WARNING



Follow **Pressure Relief Procedure**, page 13 when you stop spraying and before cleaning, checking, servicing, or transporting equipment. Read warnings, page 3.

CAUTION

Methylene chloride with formic or propionic acid is not recommended as a flushing or cleaning solvent with this gun as it will damage aluminum and nylon components.

CAUTION

Solvent left in gun air passages could result in a poor quality paint finish. Do not use any cleaning method which may allow solvent into the gun air passages.

Do not point the gun up while cleaning it.



Do not wipe the gun with a cloth soaked in solvent; ring out the excess.



Do not immerse the gun in solvent.



Do not use metal tools to clean the air cap holes as this may scratch them; scratches can distort the spray pattern.



General maintenance

- ✓ Relieve the pressure.
- ✓ Clean the fluid and air line filters daily.
- ✓ Check for any fluid leakage from the gun and fluid hoses.
- ✓ Flush the gun before changing colors and whenever you are done operating the gun.

Flushing and cleaning

Gravity and Siphon Feed Guns

1. For packages that include fluid cups, use the following chart for flushing and cleaning instructions.

Cup attachment	Instruction Manual
3M™ PPS™	310693
Gravity Cup	308792
Siphon Cup	308792
Pressure Cups	308791

2. Continue to step 8 to perform daily cleaning of the Delta Spray XT gun.

Pressure Feed Guns

WARNING



Follow **Pressure Relief Procedure**, page 13 when you stop spraying and before cleaning, checking, servicing, or transporting equipment. Read warnings, page 3.

1. Relieve the pressure, page 13.
2. Disconnect the fluid supply hose and air supply hose from the gun.

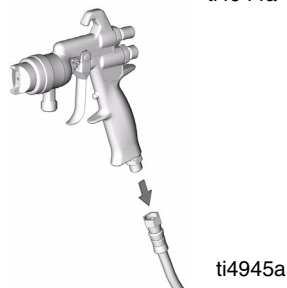
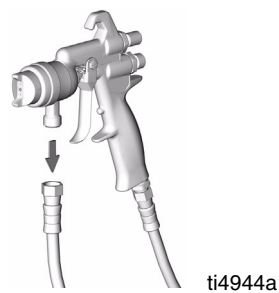
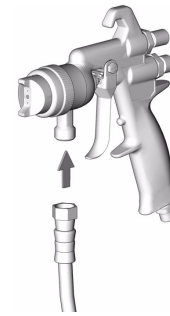

FIG. 13

3. Connect the solvent supply hose to the gun.



ti4854fix

FIG. 14

4. Hold metal part of gun against a grounded metal container, trigger, and flush the gun with solvent until all traces of paint are removed from the gun passages.

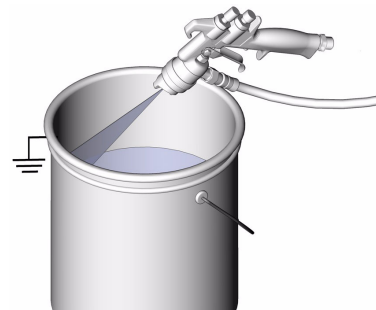

ti4836fix

FIG. 15

5. Turn off the solvent supply.
6. Relieve the pressure.
7. Disconnect the solvent supply hose from the gun.

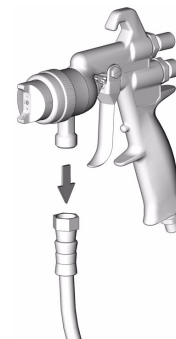

ti4944arrow

FIG. 16

8. Remove the air cap retaining ring assembly (15) and air cap (14).
9. Trigger the gun while you remove the fluid nozzle (12) from the gun with the gun tool (28)

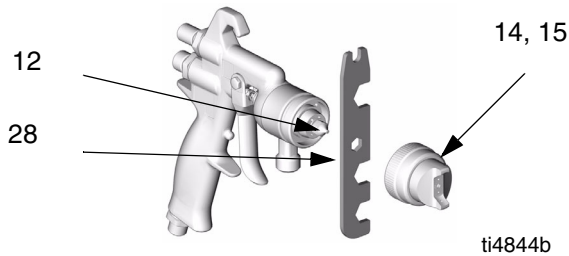

FIG. 17

CAUTION

Trigger the gun whenever you tighten or remove the nozzle. This keeps the needle seat away from the nozzle seating surface and prevents the seat from being damaged.

10. Dip the end of a soft-bristle brush into a compatible solvent. Do not continuously soak the brush's bristles with solvent and do not use a wire brush.



FIG. 18

11. With the gun pointed down, clean the front of the gun, using the soft-bristle brush and solvent.

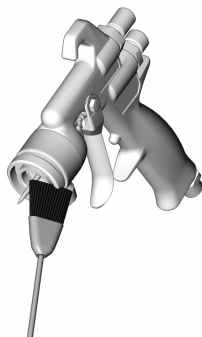

FIG. 19

12. Scrub the air cap retaining ring, air cap, and fluid nozzle with the soft-bristle brush.



FIG. 20



- To clean out air cap holes, use a soft implement, such as a toothpick, to avoid damaging critical surfaces.
- Clean the air cap and fluid nozzle daily, minimum. Some applications require more frequent cleaning.
- Do not soak the air cap retaining ring in solvent for prolonged periods of time.

13. Trigger the gun while you install the fluid nozzle (12) with the gun tool (28). Tighten the nozzle securely to 40 in-lb (4.5 N•m) to obtain a good seal.

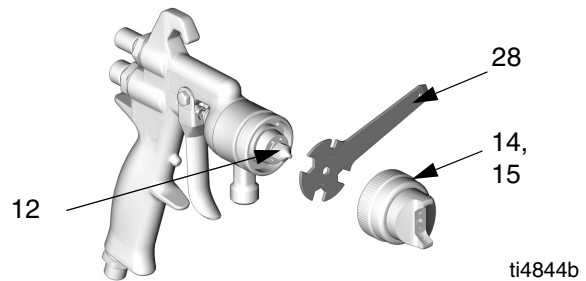
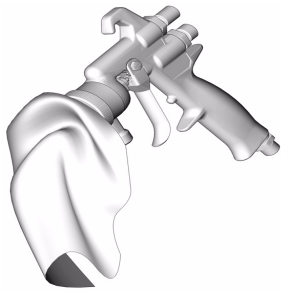

FIG. 21

14. Install the air cap retaining ring assembly (15) and air cap (14).

15. Dampen a soft cloth with solvent and wring-out the excess. Point the gun down and wipe off the outside of the gun.



ti4848a

FIG. 22

16. After cleaning the gun, lubricate the following parts with lubricant 111265 daily:

- Fluid adjustment knob threads
- Trigger pivot pin
- Fluid needle shaft

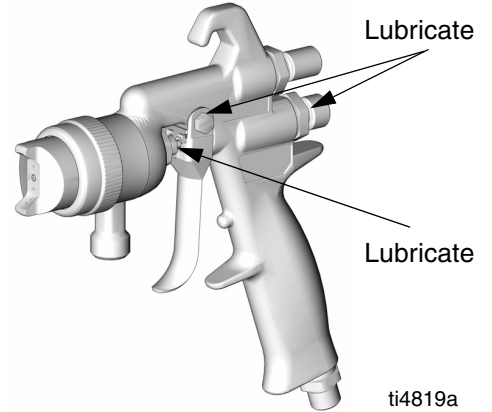

ti4819a

FIG. 23

Troubleshooting

 **WARNING**



Follow **Pressure Relief Procedure**, page 13 when you stop spraying and before cleaning, checking, servicing, or transporting equipment. Read warnings, page 3.

Problem	Cause	Solution
Fluid flow is fluttering while spraying.	<ol style="list-style-type: none"> 1. Fluid nozzle not tight enough. 2. Fluid filter clogged. 3. Fluid source empty. 	<ol style="list-style-type: none"> 1. Tighten fluid nozzle to 40 in-lb (4.5 N•m). 2. Check fluid filter. 3. Refill
Fluid flow fades while spraying high viscosity fluids.	<ol style="list-style-type: none"> 1. Air hose size is too restricted for higher air flow being used. 	<ol style="list-style-type: none"> 1. Use 5/16 in. (7.9 mm) I.D. air hose if the hose is 25 ft. (7.6 m) long. If longer hose is needed, use a 3/8 in. (9.5 mm) I.D. hose.
Pattern becomes off-set or heavy on ends.	<ol style="list-style-type: none"> 1. Air cap horn holes plugged or damaged. 2. Nozzle tip dirty or damaged. 	<ol style="list-style-type: none"> 1. Clean air cap horn holes with non-metallic item such as a toothpick, or replace air cap. 2. Clean or replace nozzle.
Gun fluid pressure is too high with gun triggered (cannot achieve desired flow rate).	Using needle/nozzle kit with too small orifice.	Use needle/nozzle kit with larger orifice.
Using a low fluid pressure setting, the fluid flow is too high, making it necessary to restrict needle travel to reduce fluid flow.	Using needle/nozzle kit with too large orifice.	Use needle/nozzle kit with smaller orifice.
Fluid system will not operate at low enough fluid pressure [below 10 psi (70 kPa, 0.7 bar)].	There is no fluid regulator, or air regulator or pressure pot is not sensitive enough at low pressures.	Add low pressure fluid regulator, or add more sensitive low pressure air regulator on pressure pot.

Service

Replacing the air and fluid packings

Tools needed:

- Gun Tool - provided
 - Packing Installation Tool - provided
 - Adjustable Wrench
 - Screw Driver
 - Lubricant part no. 111265; see Accessories, page 28, to order
 - Compatible Solvent
-  • Order Repair Kit 234828. See **Parts** starting on page 25.
- Clean parts with a solvent that is compatible with the parts and the fluid being sprayed.
 - Lightly lubricate the parts indicated with lubricant 111265.

Disassembling the gun

WARNING



Follow **Pressure Relief Procedure**, page 13 when you stop spraying and before cleaning, checking, servicing, or transporting equipment. Read warnings, page 3.

1. Relieve the pressure, page 13.

2. Flush the spray gun, page 9.
3. Remove the air cap retaining ring (15A), seal (15B), and air cap (14).

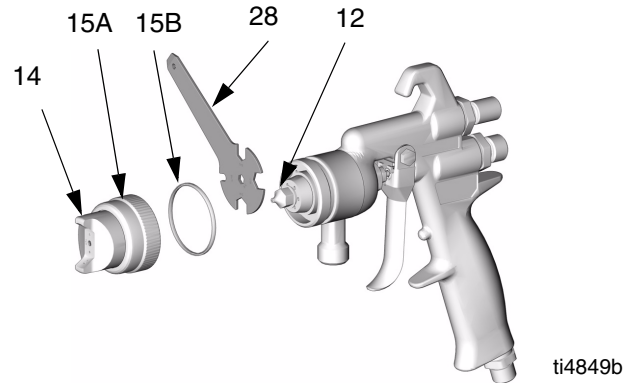

FIG. 24

4. Trigger the gun while you remove the fluid nozzle (12) with the gun tool (28). See FIG. 24.
5. Remove the screw (11), pin (17), wave washer (18), and trigger (10).

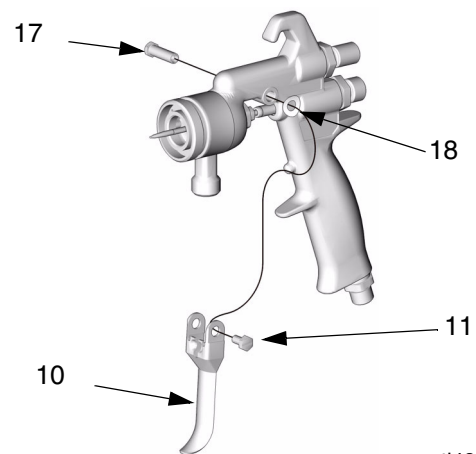

FIG. 25

6. Loosen the hex nut (9) with the gun tool (28).

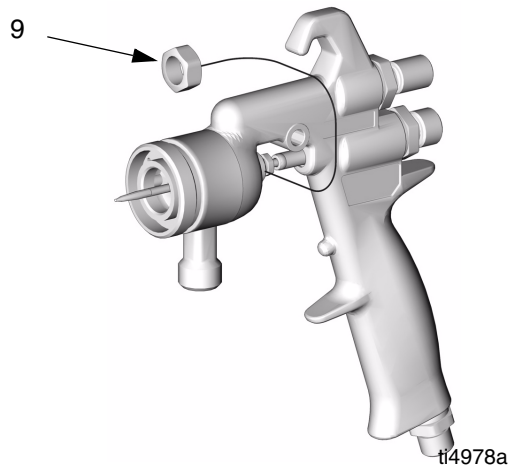

FIG. 26

7. Remove the spray housing (2A) and insert (4).

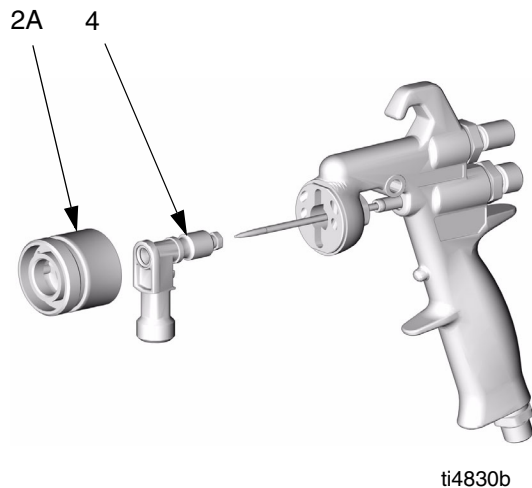

FIG. 27

Replacing the spray housing o-rings and packings

1. With the spray housing (2A) removed from the insert (4), use a mechanical pick to remove the o-ring (2B) from the housing (2A).

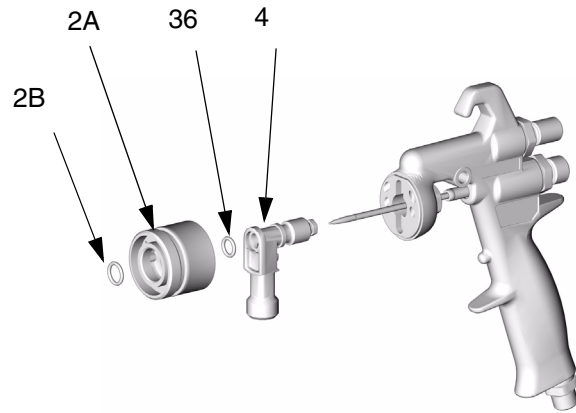

FIG. 28

2. Remove o-ring (34) from the insert (4).



O-ring (2B) is slightly larger than o-ring (34).

3. Install a new o-ring (34) into the insert (4). Install a new o-ring (2B) into the housing (2A).



NOTE: To ease o-ring installation, place the insert (4) into the spray housing (2B) to plug the end. Install one end of the o-ring into the groove in the housing, then press the rest of the o-ring into place.

- Unscrew the packing screw (8) from the insert (4) with the gun tool (28).

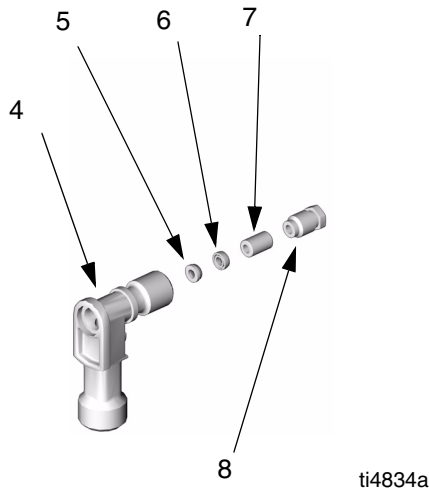

FIG. 29

- Using a mechanical pick, push the three fluid packings (5, 6, 7) out of the insert (4). Be careful not to damage the insert. Discard the old fluid packings.
- Place the new fluid packings (5, 6, 7) and packing screw (8) onto the needle (13). Note the orientation of the parts.

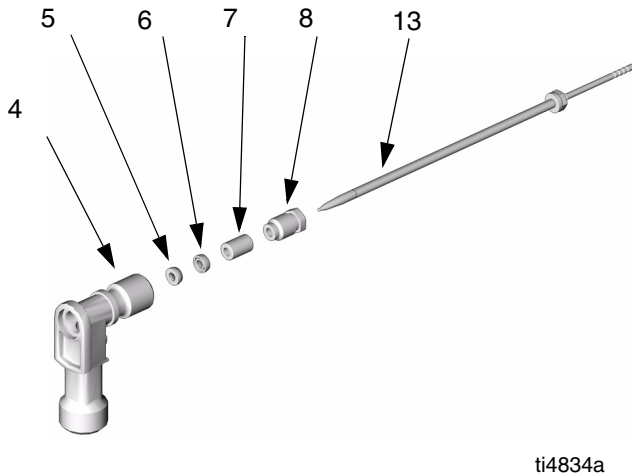

FIG. 30

- Insert the fluid needle (13) into the back of the insert (4) to install the fluid packings (5).
- Tighten the packing screw (8) just enough to hold the packings (5) in the insert (4). The needle (13) must move freely. Remove the needle.

Replacing the pattern adjustment valve packings

- Unscrew the pattern adjustment valve assembly (25 A-D).

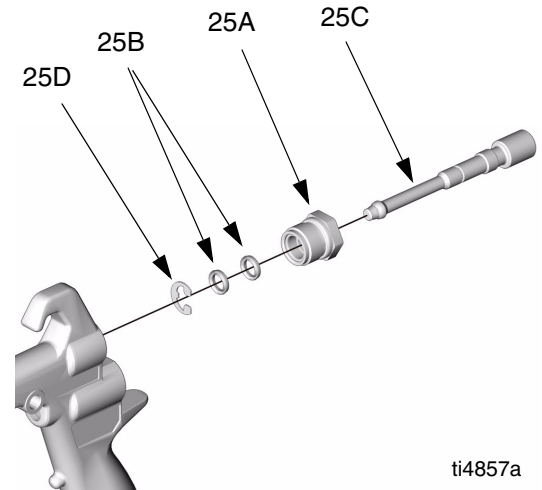

FIG. 31

- Using a needle nose pliers, remove the retaining ring (25D) and unscrew the pattern adjustment valve (25C).
- Using a mechanical pick, remove the u-cup packings (25B) from the pattern adjustment nut (25A). Be careful not to damage the seal surface or the nut's internal threads.
- One at a time, install the new u-cup packings (25B) with the packing installation tool (29); the u-cup lips must face toward the tool.

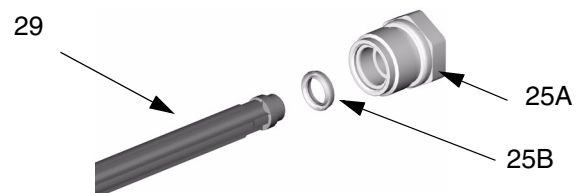

FIG. 32

- Push each u-cup packing (25B) into the pattern adjustment nut (25A) until a definite snap is felt.
- Lubricate the pattern adjustment valve (25C) threads and install the valve into the nut (25A). Install the retaining ring (25D), then back out the pattern adjustment valve as far as the retaining ring allows it to go.

Replacing the fluid valve packings

1. Remove the fluid adjustment knob (21) and fluid spring (23).
2. Pull the fluid needle (13) out the back of the gun.

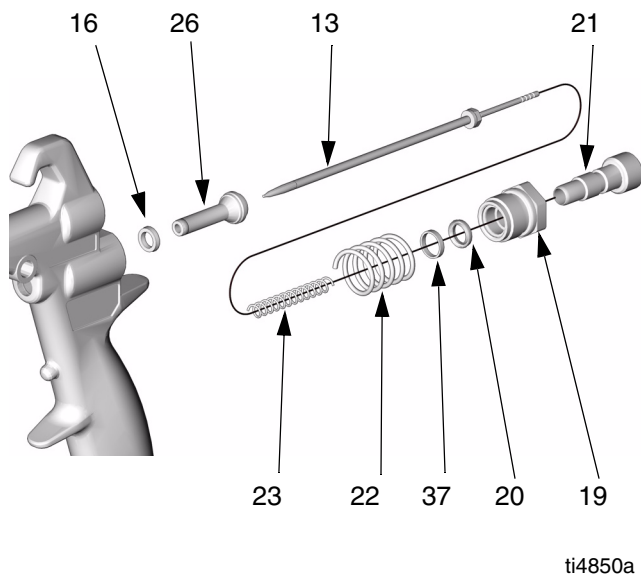

FIG. 33

3. Remove the fluid valve nut (19), air valve spring (22), and air valve assembly (26). Discard the air valve assembly. Using a mechanical pick, remove the u-cup packing (16) from the gun body.

4. Place the new u-cup packing (16) on the packing installation tool (29), with the u-cup lips facing the tool as shown.

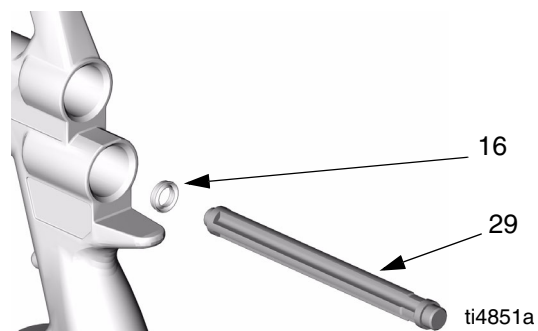

FIG. 34

5. Push the packing (16) into the back of the gun until a definite snap is felt.
6. Using a mechanical pick, remove the u-cup packing (20) and spacer (37) from the fluid valve nut (19). Be careful not to damage the seal surface or the nut's internal threads.
7. Using the packing installation tool (29), install the new spacer (37) then the new u-cup packings (20) into the fluid valve nut (19). The u-cup lips must face toward the tool as shown. This will help apply even pressure to the u-cup lips and avoid damaging them.

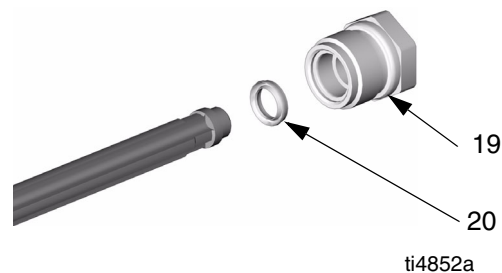



FIG. 35

8. Push the u-cup packings (20) into the fluid valve nut (19) until a definite snap is felt.

Reassembling the gun

 To ensure proper alignment of the parts, assemble parts in the exact order given in the following steps.

1. Slide the insert (4) into the spray housing (2A), and install them onto the gun body (1). Align the housing with the slot and lip (A) on the gun body.

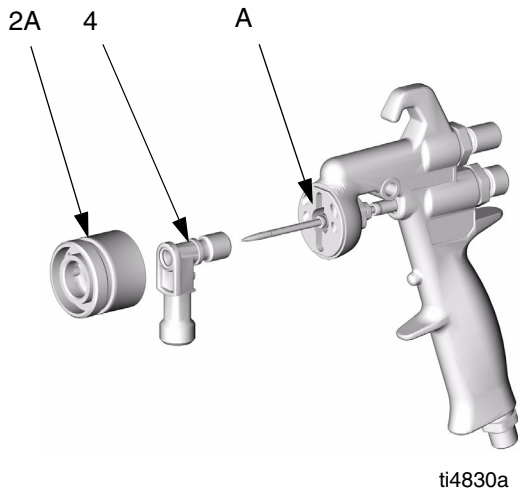

FIG. 36

2. Tighten the hex nut (9) onto the insert (4) hand-tight, then loosen the nut about one turn so the insert (4) and spray housing sit loosely in the gun body.

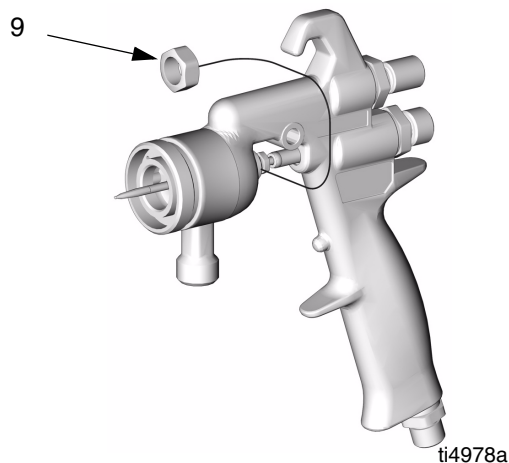

FIG. 37

3. Check the fluid needle (13) for damage or excessive wear. Replace needle tip or entire needle if necessary.

If replacing needle tip, use low strength thread adhesive on needle tip threads.

4. Lubricate the outside of the new air valve assembly (26) and place it on the fluid needle (13), against the nut (B). See FIG. 38.
5. Install the fluid needle (13) and the air valve assembly (26) into the back of the gun.

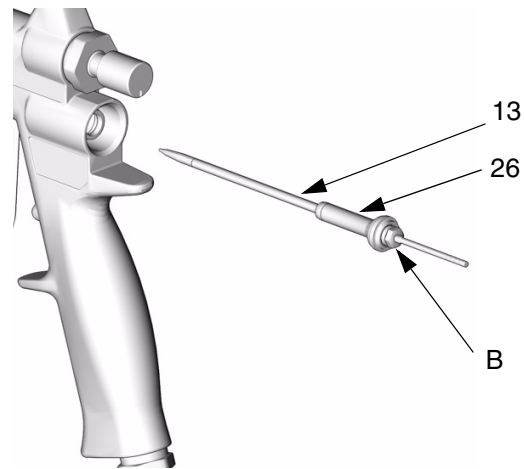

FIG. 38

6. With u-cup (20) and spacer (37) already installed into fluid nut (19), point gun down and install spring (22) and fluid nut (19). Tighten the fluid nut (19) to 125-135 in-lb (14-15 N•m).

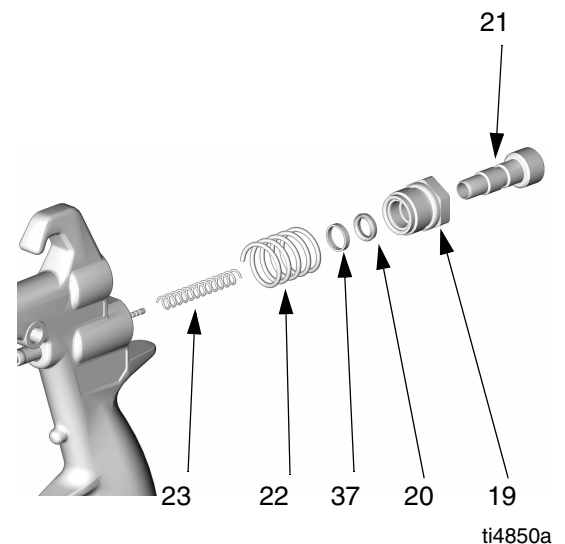

FIG. 39

7. Install needle spring (23). Install fluid adjustment knob (21).

8. Install the trigger (10), pivot pin (17), wave washer (18), and screw (11). Torque the screw to 20-30 in-lb (2.3-3.4 N•m).

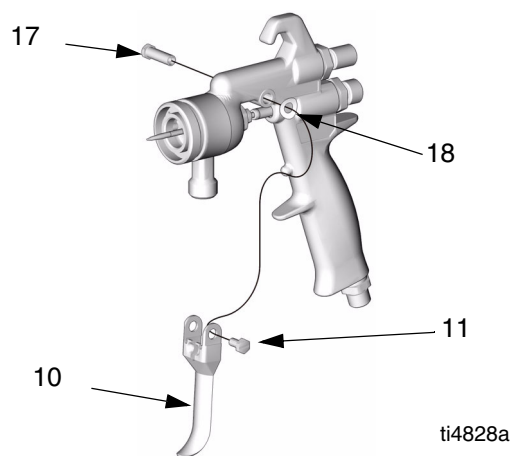

FIG. 40

9. Apply a thin film of lubricant to the fluid nozzle seat and threads.
10. Trigger the gun while you install the fluid nozzle (12) with the gun tool (28). Torque the nozzle securely to 40 in-lb (4.5 N•m).

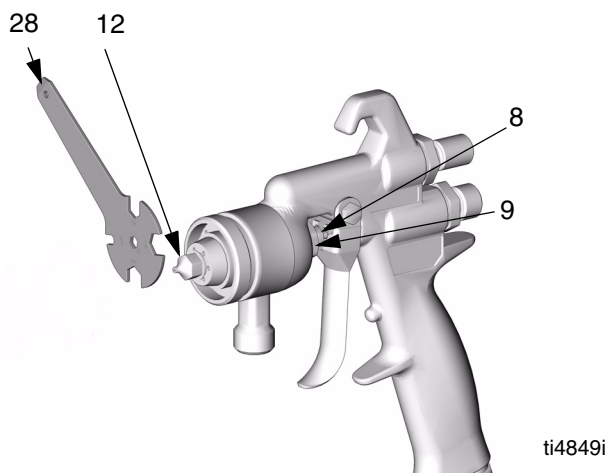

FIG. 41

11. Tighten the hex nut (9) securely to 125-135 in-lb (14-15 N•m).

12. Install the pattern adjustment valve assembly (25A-D). Torque the nut (25A) to 125-135 in-lb (14-15 N•m).

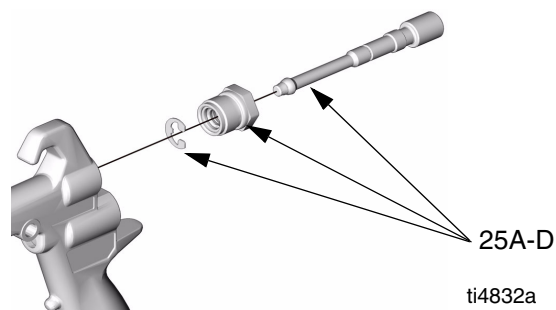

FIG. 42

13. Tighten the packing screw (8) by turning the screw in until it touches the fluid packings, then tighten one full turn to pre-set the packings. Loosen the screw, then turn it in until it touches the packings again. Tighten the screw 1/12 turn more (equal to half the distance between points on the hex head). See FIG. 41.
14. Trigger the gun to test the needle movement. If the needle does not return after the trigger is released or is slow in returning, loosen the packing screw (8) until the needle returns freely.
15. Replace seal (15B). Install the air cap (14), air cap retaining ring (15A), and seal (15B). Hand-tighten the ring.

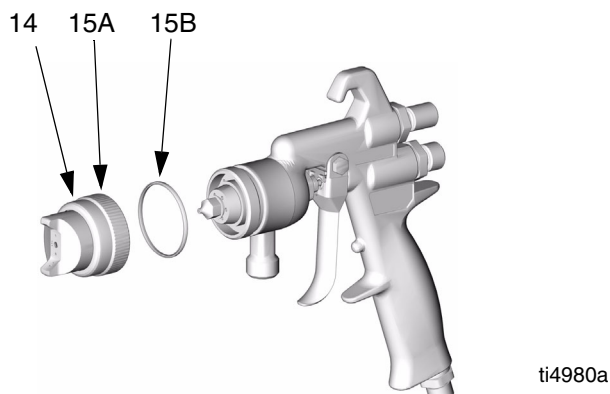

FIG. 43

16. Make sure the gun fluid packings are sealing properly by spraying solvent at low pressure before fully pressurizing the gun with the fluid to be sprayed.
17. If the fluid packings leak, tighten the packing screw (8) slightly and retest until the packings and fluid needle seal completely.



A series of horizontal lines for writing, starting from the top line and extending down to the bottom of the page.

Parts

Airspray, HVLP, and Compliant Guns

With Pressure, Gravity, and Siphon Feeds

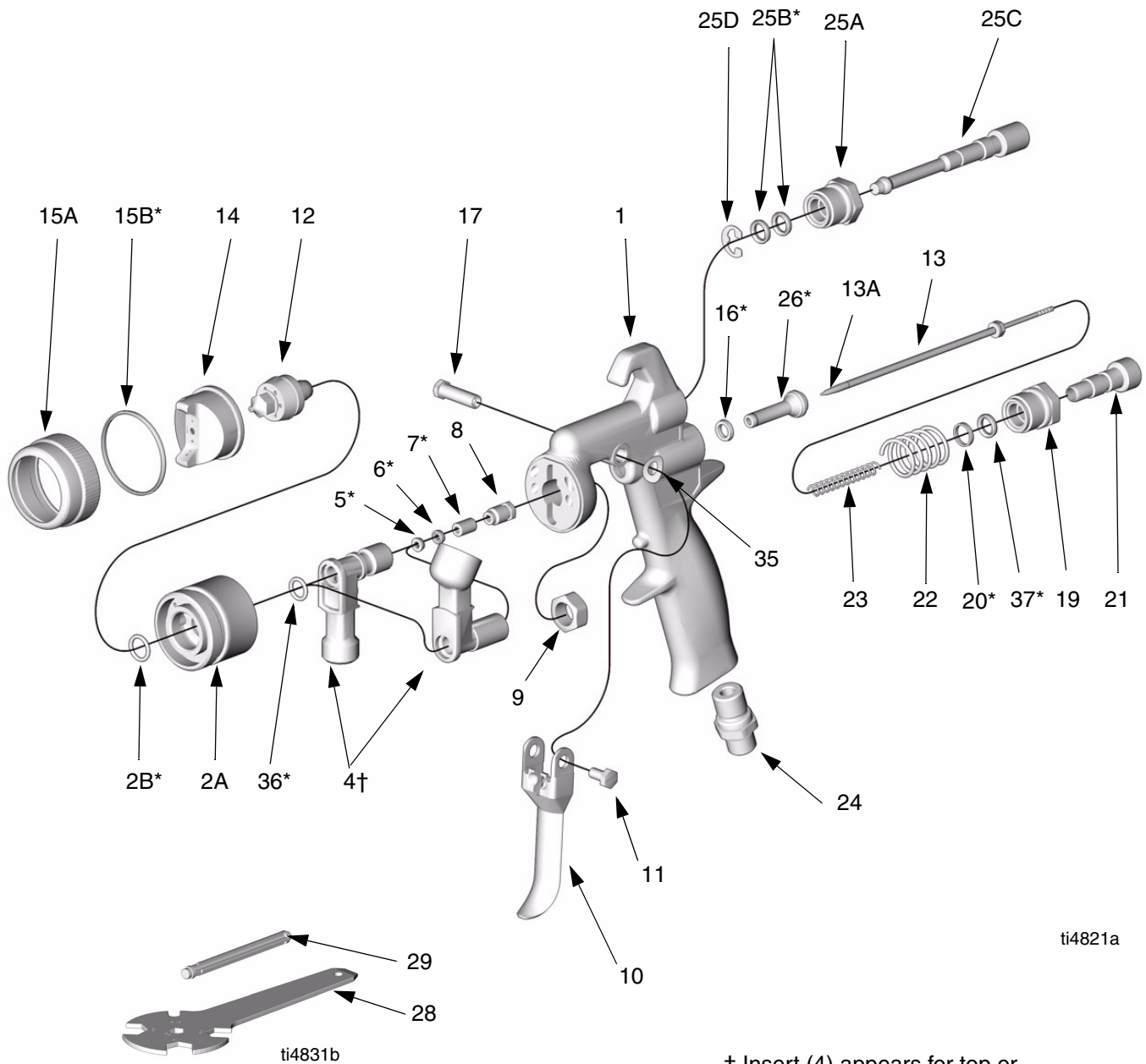

ti4821a

† Insert (4) appears for top or bottom feed depending on application.

Airspray, HVLP, and Compliant Guns

With Pressure, Gravity, and Siphon Feed

Ref. No	Part No.	Description	Qty.	Ref. No	Part No.	Description	Qty.
1	234740	BODY, gun	1	25	234379	VALVE ASSY., pattern adjustment; includes items 25A-D; airspray guns only	1
2		SPRAY HOUSING ASSY., includes items 2A-B; For part number, see chart below	1		234297	VALVE ASSY., pattern adjustment; includes items 25A-D; compliant and HVLP guns only	1
2A		HOUSING, spray;	1	25A	15C468	NUT, pattern adjustment	1
2B*	111316	O-RING	1	25B*	110453	U-CUP	2
4	15D661	INSERT, fluid; pressure and siphon feed guns only	1	25C	15C877	VALVE; Airspray gun	1
	15C463	INSERT, fluid; gravity feed guns only	1		15C469	VALVE; HVLP and Compliant guns	1
5*	188494	PACKING, spreader	1	25D	114068	RING, retaining	1
6*	188495	PACKING, u-cup	1	26*	234363	AIR VALVE ASSY.	1
7*	192351	PACKING, spacer	1	28	15E581	TOOL, gun	1
8	192352	SCREW, packing	1	29	192282	TOOL, seal installation	1
9	192348	NUT, hex; 1/2 - 20 UNF	1	35	15C480	WAVE WASHER	1
10	15D993	TRIGGER	1	36*	113137	O-RING	1
11	203953	SCREW, trigger lock	1	37*	15E246	SPACER	1
12★		NOZZLE, fluid;	1				
13★		NEEDLE ASSY.; includes item 13A	1				
13A★		TIP, needle	1				
14★		AIR CAP	1				
15	239953	RETAINING RING ASSY., includes items 15A-B	1				
15A		RING	1				
15B*		SEAL	1				
16*	188493	U-CUP	1				
17	192272	PIN, pivot	1				
19	15C468	NUT, fluid valve	1				
20*	110453	U-CUP	1				
21	15E245	KNOB, fluid adjustment	1				
22	114069	SPRING, air valve	1				
23	114072	SPRING, needle	1				
	110402	SPRING, needle; for SST needle tips	1				
24	195065	INLET, air;	1				
	15C518	INLET, air; HVLP gravity feed guns only	1				

★ See chart on pages 6 and 7 for part number.

* Parts included in Kit 234828 (purchase separately).

Gun	Spray Housing Assembly
HVLP Gravity Feed	234632
HVLP Pressure Feed	234591
Compliant Pressure/Siphon Feed	234635
Compliant Gravity Feed	234634
Airspray Pressure/Siphon Feed	234592
Airspray Gravity Feed	234633

234788 Spatter or Specking Airspray Gun

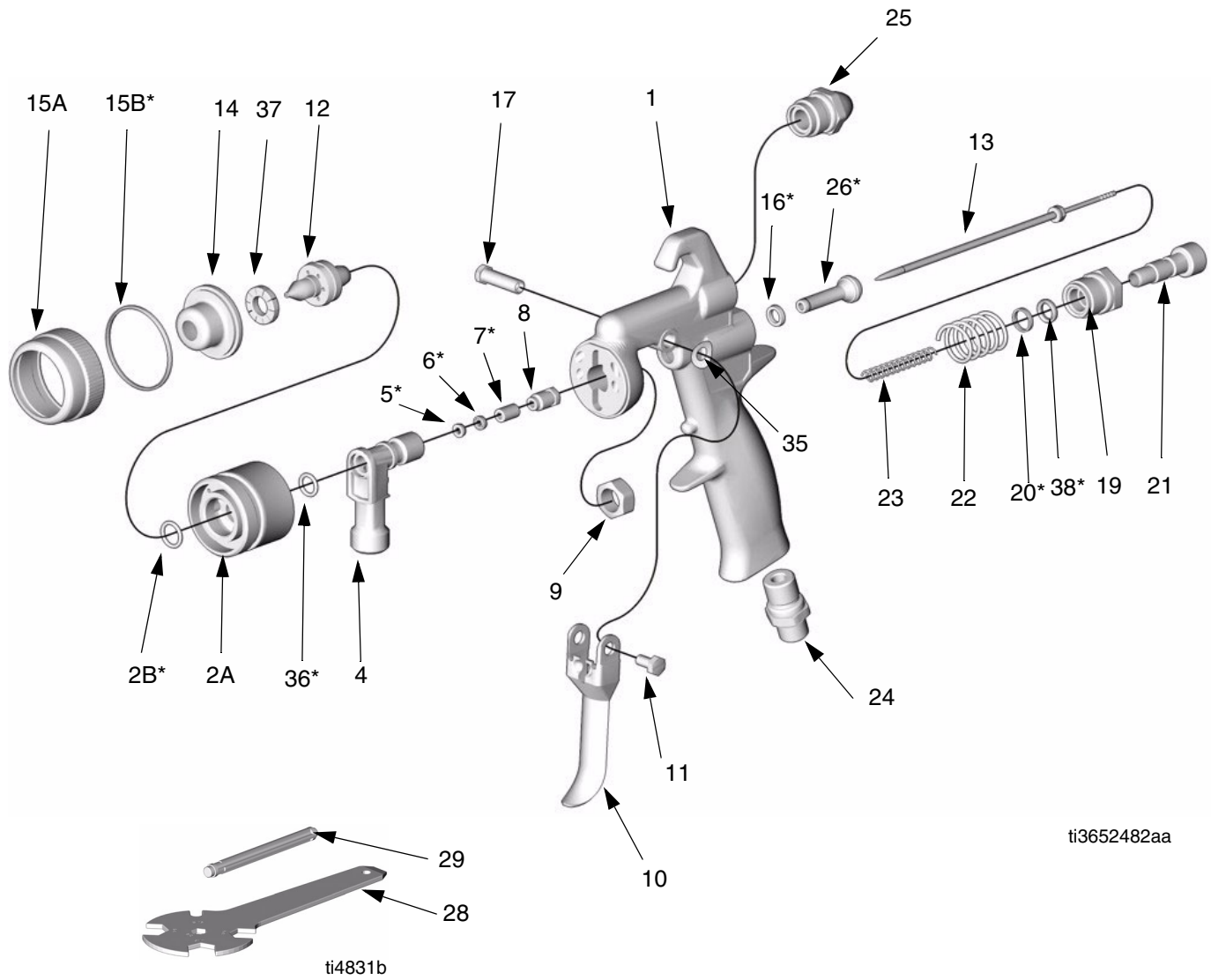

234788 Spatter or Specking Airspray Gun

Ref. No	Part No.	Description	Qty.	Ref. No	Part No.	Description	Qty.
1	234740	BODY, gun	1	16*	188493	U-CUP	1
2	234592	SPRAY HOUSING ASSY., includes items 2A-B;	1	17	192272	PIN, pivot	1
2A		HOUSING, spray;	1	19	15C468	NUT, fluid valve	1
2B*	111316	O-RING	1	20*	110453	U-CUP	2
4	15D661	INSERT, fluid;	1	21	15E245	KNOB, fluid adjustment	1
5*	188494	PACKING, spreader	1	22	114069	SPRING, air valve	1
6*	188495	PACKING, u-cup	1	23	114072	SPRING, needle	1
7*	192351	PACKING, spacer	1	24	195065	INLET, air	1
8	192352	SCREW, packing	1	25	15E138	CAP	1
9	192348	NUT, hex; 1/2 - 20 UNF	1	26*	234363	AIR VALVE ASSY.	1
10	15D993	TRIGGER	1	28	15E581	TOOL, gun	1
11	203953	SCREW, trigger lock	1	29	192282	TOOL, seal installation	1
12	15E139	NOZZLE, fluid	1	35	15C480	WAVE WASHER	1
13	239644	NEEDLE ASSY.	1	36*	113137	O-RING	1
14	196109	AIR CAP	1	37	196111	BAFFLE	1
15	239953	RETAINING RING ASSY., includes items 15A-B	1	38*	15E246	SPACER	1
15A		RING	1	* Parts included in Kit 234828 (purchase separately).			
15B*		SEAL	1				

Accessories

Cleaning Brush 105749

For use in cleaning gun

Lubricant 111265

One 4 oz. (113 gram) tube sanitary (non-silicone) lubricant for fluid seals and wear areas.

Air Control Valve Kit 243670

Install on the gun air inlet to control both the atomizing air and the pressure in the spray gun cup (if used).

1/4 npsm x 1/4-19 BSPT.

Air Control Valve 234784

Comes with gauge. Allows for air pressure adjustment at gun inlet.



HVLP Air Pressure Verification Kit

For use in checking HVLP air cap atomizing air pressure at various supply air pressures. Not to be used for actual spraying.

Install the kit air cap on the gun. Turn on the air to the gun, then trigger the gun and read the atomizing air pressure on the gauge.

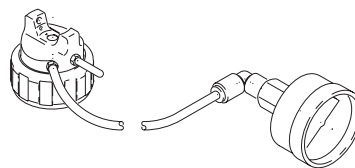

 To be HVLP compliant, the atomizing air pressure must not exceed 10 psi (70 kPa, 0.7 bar).

Kit Part Number	Orifice	Feed
234736	.030-.070 (0.8-1.8)	Pressure
234737	.086 (2.2)	Pressure
234738	.110 (2.8)	Pressure
234739	.030-.070 (0.8-1.8)	Gravity/Siphon

Gun Air Regulator Assy. 235119

0-100 psi (0-0.7 MPa, 0-7 bar) air regulator to control air pressure to gun.

 Installing the gun air regulator adds a pressure drop that could limit the air cap pressure.

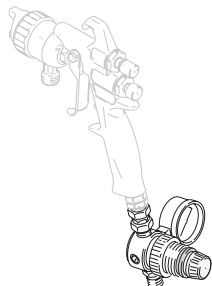

Gravity Cup

For use with gravity feed gun. Nylon cup, 304 stainless steel 3/8 npsm(f) fluid inlet fitting, fluid filter cartridge included.

Part Number	Size
239714	16 oz. (474 cc)
239715	8 oz. (237 cc)

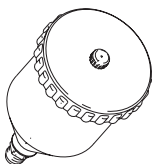

Gravity Cup Holder Bracket 192407

Fits both gravity cup sizes.

SST Pressure Cup Kit 239802 with single air regulator

1 qt. (0.95 liter) capacity, 304 stainless steel cup. Includes a pressure relief valve and a single air regulator and gauge.

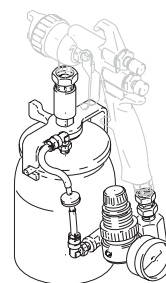

1 Quart Remote SST Pressure Cup 239804

1 qt. (0.95 liter) capacity, 304 stainless steel cup.

Includes air pressure regulator and gauge, 4 ft. (1.2 m) length air and fluid hose with 1/4 npsm(f) swivel ends, pressure relief valve, and rigid hook handle.

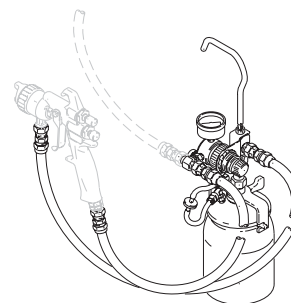

SST Pressure Cup Kit 239803 with double air regulator

1 qt. (0.95 liter) capacity, 304 stainless steel cup.
Includes a pressure relief valve, a 0-100 psi (0-0.7 MPa, 0-7 bar) air regulator for gun atomization, and a 0-15 psi (0-104 kPa, 0-1.0 bar) air regulator for the 1 qt. pressure cup supply air.

 Installing the pressure cup kit adds a pressure drop that could limit the air cap pressure.

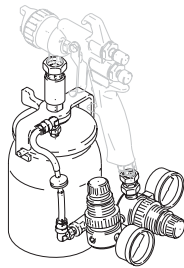

3M™ PPS™ Paint Preparation System

Gravity Feed 234837

Siphon Feed 234773

For use with gravity feed gun. Includes PPS cup, liner, and adapter. See instruction manual 310693 for more information.

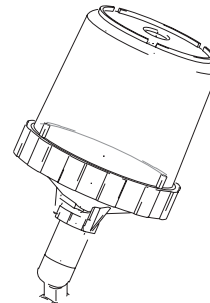

Gravity Feed

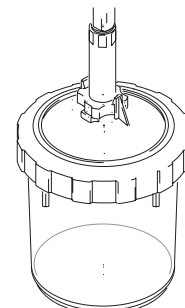

Siphon Feed

Disposable Polyethylene Cup Liners

Paint and solvent resistant. 40 Liners per box.

112490 - 1 Quart Size

112491 - 2 Quart Size

Fluid Shut Off Spring 110402

Replaces standard spring 114072 when using SST needle tips, and provides increased shut off force in difficult applications.

Technical Data

Category	Data
Maximum Working Fluid Pressure	300 psi (2.1 MPa, 21 bar)
Maximum Working Air Pressure	100 psi (0.7 MPa, 7 bar)
Maximum Compliant Inbound Air Pressure	29 psi (200 kPa, 2.0 bar)
HVLP Gravity/Siphon Feeds	29 psi (200 kPa, 2.0 bar)
HVLP Pressure Feed	40 psi (280 kPa, 2.8 bar)
Fluid and Air Operating Temperature Range	32°F to 109°F (0°C to 43°C)
Weight	22.3 oz. (632 g)
Air Inlet	1/4-18 npsm
Fluid Inlet	3/8 npsm
Wetted Parts	304, 303, 17-4 PH Stainless Steel, PEEK, Acetal, Ultra High Molecular Weight Polyethylene
Noise Data*	
Sound Pressure	84.4 Db(A)
Sound Power	94.0 Db(A)
Air Consumption Gravity/Siphon Feed:	
<i>Airspray</i> at 50 psi inlet	14.1 scfm
<i>HVLP</i> at 29 psi inlet	15.5 scfm
<i>Compliant</i> at 29 psi inlet	11.2 scfm
Air Consumption Pressure Feed:	
<i>Airspray</i> at 40 psi inlet	12.5 scfm
<i>HVLP</i> at 40 psi inlet	21.0 scfm
<i>Compliant</i> at 29 psi inlet	11.2 scfm

*All readings were taken with the gun controls fully open and with 40 psi (280 kPa, 2.8 bar). Sound pressure was tested to CAGI-PNUEROP-1969. Sound power was tested to ISO 3744-1981.

Graco Standard Warranty

Graco warrants all equipment referenced in this document which is manufactured by Graco and bearing its name to be free from defects in material and workmanship on the date of sale to the original purchaser for use. With the exception of any special, extended, or limited warranty published by Graco, Graco will, for a period of twelve months from the date of sale, repair or replace any part of the equipment determined by Graco to be defective. This warranty applies only when the equipment is installed, operated and maintained in accordance with Graco's written recommendations.

This warranty does not cover, and Graco shall not be liable for general wear and tear, or any malfunction, damage or wear caused by faulty installation, misapplication, abrasion, corrosion, inadequate or improper maintenance, negligence, accident, tampering, or substitution of non-Graco component parts. Nor shall Graco be liable for malfunction, damage or wear caused by the incompatibility of Graco equipment with structures, accessories, equipment or materials not supplied by Graco, or the improper design, manufacture, installation, operation or maintenance of structures, accessories, equipment or materials not supplied by Graco.

This warranty is conditioned upon the prepaid return of the equipment claimed to be defective to an authorized Graco distributor for verification of the claimed defect. If the claimed defect is verified, Graco will repair or replace free of charge any defective parts. The equipment will be returned to the original purchaser transportation prepaid. If inspection of the equipment does not disclose any defect in material or workmanship, repairs will be made at a reasonable charge, which charges may include the costs of parts, labor, and transportation.

THIS WARRANTY IS EXCLUSIVE, AND IS IN LIEU OF ANY OTHER WARRANTIES, EXPRESS OR IMPLIED, INCLUDING BUT NOT LIMITED TO WARRANTY OF MERCHANTABILITY OR WARRANTY OF FITNESS FOR A PARTICULAR PURPOSE.

Graco's sole obligation and buyer's sole remedy for any breach of warranty shall be as set forth above. The buyer agrees that no other remedy (including, but not limited to, incidental or consequential damages for lost profits, lost sales, injury to person or property, or any other incidental or consequential loss) shall be available. Any action for breach of warranty must be brought within two (2) years of the date of sale.

GRACO MAKES NO WARRANTY, AND DISCLAIMS ALL IMPLIED WARRANTIES OF MERCHANTABILITY AND FITNESS FOR A PARTICULAR PURPOSE, IN CONNECTION WITH ACCESSORIES, EQUIPMENT, MATERIALS OR COMPONENTS SOLD BUT NOT MANUFACTURED BY GRACO. These items sold, but not manufactured by Graco (such as electric motors, switches, hose, etc.), are subject to the warranty, if any, of their manufacturer. Graco will provide purchaser with reasonable assistance in making any claim for breach of these warranties.

In no event will Graco be liable for indirect, incidental, special or consequential damages resulting from Graco supplying equipment hereunder, or the furnishing, performance, or use of any products or other goods sold hereto, whether due to a breach of contract, breach of warranty, the negligence of Graco, or otherwise.

FOR GRACO CANADA CUSTOMERS

The Parties acknowledge that they have required that the present document, as well as all documents, notices and legal proceedings entered into, given or instituted pursuant hereto or relating directly or indirectly hereto, be drawn up in English. Les parties reconnaissent avoir convenu que la rédaction du présente document sera en Anglais, ainsi que tous documents, avis et procédures judiciaires exécutés, donnés ou intentés, à la suite de ou en rapport, directement ou indirectement, avec les procédures concernées.

Graco Information

TO PLACE AN ORDER, contact your Graco distributor or call to identify the nearest distributor.

Phone: 612-623-6921 or **Toll Free:** 1-800-328-0211, **Fax:** 612-378-3505

*All written and visual data contained in this document reflects the latest product information available at the time of publication.
Graco reserves the right to make changes at any time without notice.*

MM 310692

Sales Office: Minneapolis

International Offices: Belgium, China, Japan, Korea

GRACO INC. P.O. BOX 1441 MINNEAPOLIS, MN 55440-1441

www.graco.com

Printed in USA 310692G

3/2006